



N

NOVATEC®

QUALITY • PERFORMANCE • RELIABILITY



NOVATEC®

QUALITY • PERFORMANCE • RELIABILITY

READY TO RACE

Leicht, schnell und steif. Sicher, robust und komfortabel. Die Anforderungen, die an Laufräder gestellt werden sind enorm.

Novatec schafft den Spagat und bietet durch die Bank Laufräder, die ein hochattraktives Verhältnis von Preis und Leistung anbieten. Als Technologieführer ist es selbstverständlich, dass Novatec seine eigene Topmodellnabe verbaut. Spitzensportler aus den unterschiedlichsten Disziplinen setzen seit Jahren auf die Laufräder von Novatec.

Light, fast and stiff. Safe, robust and comfortable. The requirements on wheels which are demanded are enormous.

Novatec can build the bridge and offers different wheels, which have an attractive price-performance ratio. It goes without saying that technology leader Novatec installs their own top-of-the-range hubs. Top athletes participating in different disciplines have been counting on wheels of Novatec for years.



R3 DISC

Langdistanz im Dauersprint! Mit 38 mm hohen Carbon-Felgen gleitet der Allrounder über die Straßen und macht selbst im tiefen Sand eine herausragende Figur. Das asymmetrische Felgengedesign verspricht die perfekte Kraftaufnahme der Scheibenbremse und des Antritts auf der Antriebsseite. Die Felgen sind Tubeless-Ready und kommen gänzlich ohne Felgenband aus. Das Herzstück, die Nabe, setzt auf den bewährten Anti Bite-Guard und vier Lager höchster Güte. Felgen und Naben werden mit Straightpull-Aero Speichen in konzentrierter Handarbeit verbunden. Einzigartig ist, dass jedes einzelne Laufrad mit einem Einspeich-Protokoll diese Qualität belegt.

Long distance in a permanent sprint! With 38 mm high carbon rims, the all-rounder floats along the streets and makes an outstanding figure even in deep sand. The asymmetric rim design promises the perfect power absorption of the disc brake and the acceleration on the drive side. The rims are tubeless-ready and are completely without rim tape. The heart, the hub, relies on the proven anti-bite guard and four bearings of the highest quality. Rims and hubs are combined with straight pull aero spokes in concentrated manual work. What is unique is that every single wheel with a spoking protocol proves this quality.

384125 LAUFRADSATZ ›R9 U3.0‹

UVP 1.999,00 €



Naben:

- mit **Titan**-Schnellspannern
- **Aluminium**-Dichtungsscheiben

vorne:

- 2 **austauschbare, japanische Industriekugellager**

hinten:

- 4 **austauschbare, japanische Industriekugellager**
- für 8/9/10/11-fach Kassette für Shimano oder Sram (Road+MTB)
- **rot eloxierter, austauschbarer** Kassettenkörper (Art. 326297 = Shimano/Sram, Art. 326293 = Sram XD, Art. 326298 = Campagnolo), mit **Anti Bite Guard**

Felgen:

- Carbon-Hohlkammerfelge, UD-finish
- für **Draht-/Kevlarreifen**
- **Tubeless ready**
- 700C
- Höhe **90 mm**
- vorne 16 Loch / hinten 20 Loch

Speichen:

- Straight Pull **Aero**-Speichen
- Aluminium Nippel

Extras:

- **inkl. Bremsschuhe**
- **inkl. Ventilverlängerung**
- inkl. Ersatzspeichen
- inkl. Ersatznippel

max. Fahrergewicht **110 kg**

WHEEL SET ›R9 U3.0‹

Hubs:

- with **titanium** QRs
- **aluminium** side caps

front:

- 2 **exchangeable, Japanese sealed bearings**

rear:

- 4 **exchangeable, Japanese sealed bearings**
- for 8/9/10/11-speed Shimano or Sram cassette (Road+MTB)
- **red anodized, replaceable** cassette body (art. 326297 = Shimano/Sram, art. 326293 Sram XD, art. 326298 = Campagnolo), with **Anti Bite Guard**

Rims:

- carbon double wall, UD finish
- for **clinchers/Kevlar tires**
- **tubeless ready**
- 700C
- height **90 mm**
- front 16 hole / rear 20 hole

Spokes:

- straight pull **aero** spokes
- aluminium nipples

Extras:

- **incl. brake shoes**
- **incl. valve extender**
- incl. replacement spokes
- incl. replacement nipples

max. riders weight **110 kg**

Tested by the manufacturer based on ISO 4210

TUBELESS READY



1.940 g



880 g



1.060 g



Cyclo Cross	Sprint	Endurance	Aero / Time Trial
-------------	--------	-----------	-------------------

384126 LAUFRADSATZ ›R5 U3.0‹

UVP 1.899,00 €



Naben:

- mit **Titan**-Schnellspannern
- **Aluminium**-Dichtungsscheiben

vorne:

- 2 **austauschbare, japanische Industriekugellager**

hinten:

- 4 **austauschbare, japanische Industriekugellager**
- für 8/9/10/11-fach Kassette für Shimano oder Sram (Road+MTB)
- **rot eloxierter, austauschbarer** Kassettenkörper (Art. 326297 = Shimano/Sram, Art. 326293 = Sram XD, Art. 326298 = Campagnolo), mit **Anti Bite Guard**

Felgen:

- Carbon-Hohlkammerfelge, UD-finish
- **Tubeless ready**
- 700C
- Höhe **50 mm**
- vorne 20 Loch / hinten 24 Loch
- für Drahtreifen

Speichen:

- Straight Pull **Aero**-Speichen
- Aluminium Nippel

Extras:

- **inkl. Bremsschuhe**
- **inkl. Ventilverlängerung**
- inkl. Ersatzspeichen
- inkl. Ersatznippel

max. Fahrergewicht **110 kg**

WHEEL SET ›R5 U3.0‹

Hubs:

- with **titanium** QRs
- **aluminium** side caps

front:

- 2 **exchangeable, Japanese sealed bearings**

rear:

- 4 **exchangeable, Japanese sealed bearings**
- for 8/9/10/11-speed Shimano or Sram cassette (Road+MTB)
- **red anodized, replaceable** cassette body (art. 326297 = Shimano/Sram, art. 326293 = Sram XD, art. 326298 = Campagnolo), with **Anti Bite Guard**

Rims:

- carbon double wall, UD finish
- **tubeless ready**
- 700C
- height **50 mm**
- front 20 hole / rear 24 hole
- for clinchers

Spokes:

- straight pull **aero** spokes
- aluminium nipples

Extras:

- **incl. brake shoes**
- **incl. valve extender**
- incl. replacement spokes
- incl. replacement nipples

max. riders weight **110 kg**

Tested by the manufacturer based on ISO 4210

UCI APPROVED

TUBELESS READY



1.707 g



758 g



949 g

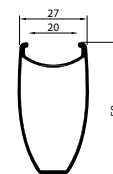

Cyclo Cross	Sprint	Endurance	Aero / Time Trial
-------------	--------	-----------	-------------------

LAUFRADSATZ ›R3‹

Naben:

- Aluminium-Dichtungsscheiben
- vorne:**
- 2 austauschbare, japanische Industriekugellager
- hinten:**
- 4 austauschbare, japanische Industriekugellager

Felgen:

- Carbon-Hohlkammerfelge, UD-finish
- **Tubeless ready**
- 700C
- Höhe **38 mm**
- für Drahtreifen

Speichen:

- Straight Pull **Aero**-Speichen
- schwarze Aluminium-Nippel

max. Fahrergewicht **110 kg**

384213 ›R3 CLIN DISC U4.0‹

UVP 1.599,00 €

Naben:

- für **Centerlock** Bremsscheiben
- **UD Carbon**
- **Bremsscheibenaufnahme**
- vorne:**
- Einbaumaß: 12 x 100 mm
- hinten:**
- Einbaumaß: 12 x 142 mm

- **4 in 1:** serienmäßig vorbereitet für 12 x 142 mm-Steckachse, Umrüstset für Schnellspanner 5 mm (Art. 320291), 10 x 135 mm, 12 x 135 mm optional erhältlich
- für 10- und 11-fach (Shimano Road und MTB)
- umrüstbar auf Sram XD Drive durch Kassettenkörper Art. 326293

Felgen:

- **asymmetrisches Felgen-Design** damit Speichen auf Zahnkranzseite weniger steil sind
- vorne 24 Loch / hinten 24 Loch

Extras:

- inkl. Ersatzspeichen
- inkl. Ersatznippel

Cyclo Cross	Sprint	Endurance	Aero / Time Trial
-------------	--------	-----------	-------------------

384133 ›R3 U3.0‹

UVP 1.499,00 €

Naben:

- mit **Titan**-Schnellspannern
- Aluminium
- Einbaumaß vorne: 100 mm
- Einbaumaß hinten: 130 mm
- hinten:**
- für 8/9/10/11-fach Kassette für Shimano oder Sram (MTB+Road)
- **rot eloxierter, austauschbarer** Kassettenkörper (Art. 326297 = Shimano/Sram, Art. 326293 = Sram XD, Art. 326298 = Campagnolo), mit **Anti Bite Guard**

Felgen:

- vorne 20 Loch / hinten 24 Loch
- für Felgenbremsen

Extras:

- **inkl. Bremsschuhe**
- inkl. Ersatzspeichen
- inkl. Ersatznippel

Cyclo Cross	Sprint	Endurance	Aero / Time Trial
-------------	--------	-----------	-------------------

WHEEL SET ›R3‹

Hubs:

- aluminium side caps
- front:**
- 2 exchangeable, Japanese sealed bearings
- rear:**
- 4 exchangeable, Japanese sealed bearings

Rims:

- carbon double wall, UD finish
- **tubeless ready**
- 700C
- height **38 mm**
- for clinchers

Spokes:

- straight pull **aero** spokes
- black aluminium nipples

max. riders weight **110 kg**

›R3 CLIN DISC U4.0‹

Hubs:

- for **centerlock** brake discs
- **UD carbon**
- **disc brake mount**
- front:**
- OLD front: 12 x 100 mm
- rear:**
- OLD: 12 x 142 mm
- **4 in 1:** standard fitted for 12 x 142 mm thru axle, conversion kit for QR 5 mm (art. 320291), 10 x 135 mm, 12 x 135 mm optionally available
- for 10 and 11 speed (Shimano Road and MTB)
- convertible to Sram XD Drive by cassette body art. 326293

Rims:

- **asymmetric rim design** so the spokes are not too steep
- front 24 hole / rear 24 hole

Extras:

- incl. replacement spokes
- incl. replacement nipples

Tested by the manufacturer based on ISO 4210

TUBELESS READY



665 g



813 g

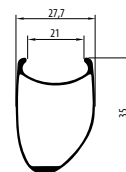

660 g



840 g

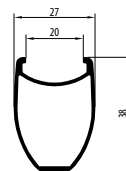

UCI APPROVED

LAUFRADSATZ 28" ›JETFLY‹

Naben:

- Aluminium-Dichtungsscheiben
- 2/4 austauschbare, japanische Industriekugellager
- für 8/9/10/11-fach Kassette für Shimano oder Sram (MTB+Road)
- rot eloxierter, austauschbarer Aluminium Kassettenkörper (Art. 326297 = Shimano/ Sram, Art. 326293 = Sram XD, Art. 326298 = Campagnolo), mit Anti Bite Guard

Felgen:

- Aluminium-Hohlkammerfelge
- Tubeless ready
- 700C
- für Drahtreifen

Speichen:

- Nirosta doppelkonifiziert
- Aluminium Nippel

384179 ›JETFLY DISC U4.0‹

UVP 799,00 €

Naben:

- Bremsscheibenaufnahme vorne:
- 4 in 1: vorbereitet für 12 mm Steckachse, optional umrüstbar durch Ausgleichshülsen für 5 mm (Art. 320117) oder 9 mm (Art. 320118) Schnellspanner und 15 mm (Art. 320120) Steckachse
- Einbaumaß: 12 x 100 mm

hinten:

- 4 in 1: vorbereitet für 12 mm Steckachse, optional umrüstbar durch Umrüstsets für 5 mm Schnellspanner (Art. 320112), 10 mm (Art. 320079) und 12x135 mm Steckachse (Art. 320080)
- Einbaumaß: 12 x 142 mm

Felgen:

- asymmetrisches Felgen-Design
- Höhe 31,8 mm
- vorne 24 Loch / hinten 28 Loch

Extras:

inkl. Ersatzspeichen, -nippel und Tubelessventil

max. Fahrergewicht 110 kg

WHEEL SET 28" ›JETFLY‹

Hubs:

- aluminium side caps
- 2/4 exchangeable, Japanese sealed bearings
- for 8/9/10/11-speed Shimano or Sram cassette (MTB+Road)
- red anodized, replaceable aluminium cassette body (art. 326297 = Shimano/ Sram, art. 326293 = Sram XD, art. 326298 = Campagnolo), with Anti Bite Guard

Rims:

- aluminium double wall
- tubeless ready
- 700C
- for clinchers

Spokes:

- double butted stainless steel
- aluminium nipples

›JETFLY DISC U4.0‹

Hubs:

- disc brake mount front:
- 4 in 1: prepared for 12 mm thru axle, optionally convertible through spacers to 5 mm (art. 320117) or 9 mm (art. 320118) QR and 15 mm thru axle (art. 320120)
- OLD: 12 x 100 mm

rear:

- 4 in 1: prepared for 12 mm thru axle, optionally convertible through spacers to 5 mm QR (art. 320112), 10 mm (art. 320079) and 12x135 mm thru axle (art. 320080)
- OLD: 12 x 142 mm

Rims:

- asymmetric rim design
- height 31.8 mm
- front 24 hole / rear 28 hole

Extras:

incl. replacement spokes, nipples and tubeless valve

max. riders weight 110 kg

Tested by the manufacturer based on ISO 4210

TUBELESS READY



800 g



945 g

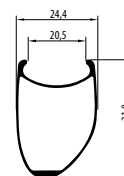

583 g



760 g

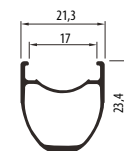

Cyclo Cross	Sprint	Endurance	Aero / Time Trial
-------------	--------	-----------	-------------------

384182 JETFLY SL‹

UVP 799,00 €

Naben:

- inkl. Schnellspanner
- Einbaumaß vorne: 5 x 100 mm
- Einbaumaß hinten: 5 x 130 mm

Felgen:

- vorne 20 Loch / hinten 24 Loch
- mit aufgerauten Bremsflanken

Speichen:

- hinten asymmetrisch 8/16 Loch eingespeicht

Extras:

inkl. Ersatzspeichen und -nippel

max. Fahrergewicht 90 kg

›JETFLY SL‹

Hubs:

- incl. QRs
- OLD front: 5 x 100 mm
- OLD rear: 5 x 130 mm

Rims:

- front 20 hole / rear 24 hole
- grooved braking sides

Spokes:

- rear wheel with asymmetrical 8/16 hole spokes pattern

Extras:

inkl. replacement spokes and nipples

max. riders weight 90 kg

Cyclo Cross	Sprint	Endurance	Aero / Time Trial
-------------	--------	-----------	-------------------

384181 LAUFRADSATZ 28"

›CXD U4.0‹

UVP 799,00 €

Naben:

- Aluminium-Dichtungsscheiben
- Bremsscheibenaufnahme

vorne:

- **4 in 1:** vorbereitet für **12 mm Steckachse**, optional umrüstbar durch Ausgleichshülsen für 5 mm (Art. 320117) oder 9 mm (Art. 320118) Schnellspanner und 15 mm (Art. 320120) Steckachse
- **2 austauschbare, japanische Industriekugellager**
- Einbaumaß: 12 x 100 mm

hinten:

- **4 in 1:** vorbereitet für **12 mm Steckachse**, optional umrüstbar durch Umrüstsets für 5 mm Schnellspanner (Art. 320112), 10 mm (Art. 320079) und 12x135 mm Steckachse (Art. 320080)
- **4 austauschbare, japanische Industriekugellager**
- Einbaumaß: 12 x 142 mm
- für **8/9/10/11-fach** Shimano oder Sram Kassette (MTB+Road)
- **rot eloxierter, austauschbarer** Aluminium Kassettenkörper (Art. 326297 = Shimano/Sram, Art. 326293 = Sram XD, Art. 326298 = Campagnolo), mit Anti Bite Guard

Felgen:

- **asymmetrisches Felgen-Design**
- Aluminium-Hohlkammerfelge
- **Tubeless ready**
- 700C
- Höhe 24 mm
- vorne 20 Loch / hinten 24 Loch
- für Drahtreifen

Speichen:

- **Nirosta doppelkonifiziert**
- mit **schwarzen Aluminium** Nippeln

Extras:

inkl. Ersatzspeichen, -nippel und Tubelessventil

max. Fahrergewicht **110 kg**

WHEEL SET 28"

›CXD U4.0‹

Hubs:

- **aluminium** side caps
- **disc brake mount front:**

front:

- **4 in 1:** prepared for **12 mm thru axle**, optionally convertible through spacers to 5 mm (art. 320117) or 9 mm (art. 320118) QR and 15 mm thru axle (art. 320120)
- **2 exchangeable, Japanese sealed bearings**
- OLD: 12 x 100 mm

rear:

- **4 in 1:** prepared for **12 mm thru axle**, optionally convertible through spacers to 5 mm QR (art. 320112), 10 mm (art. 320079) and 12x135 mm thru axle (art. 320080)
- **4 exchangeable, Japanese sealed bearings**
- OLD: 12 x 142 mm
- for **8/9/10/11-speed** Shimano or Sram cassette (MTB+Road)
- **red anodized, replaceable** aluminium cassette body (art. 326297 = Shimano/Sram, art. 326293 = Sram XD, art. 326298 = Campagnolo), with Anti Bite Guard

Rims:

- **asymmetric rim design**
- aluminium double wall
- **tubeless ready**
- 700C
- height 24 mm
- front 20 hole / rear 24 hole
- for clinchers

Spokes:

- **double butted stainless steel**
- with **black aluminium** nipples

Extras:

incl. replacement spokes, nipples and tubeless valve

max. riders weight **110 kg**

Tested by the manufacturer based on ISO 4210

TUBELESS READY

CYCLO CROSS **DISC**



1.615 g



734 g



881 g

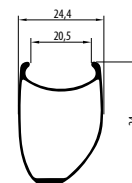

Cyclo Cross	Sprint	Endurance	Aero / Time Trial
-------------	--------	-----------	-------------------



LAUFRADSATZ ›30◀

Felgen:

- Aluminium-Hohlkammerfelge
- Tubeless ready
- 700C
- Höhe 30 mm
- vorne 24 Loch / hinten 28 Loch
- für Drahtreifen

Speichen:

- schwarz
- mit Aluminium Nippeln

max. Fahrergewicht **110 kg**

WHEEL SET ›30◀

Rims:

- aluminium double wall
- tubeless ready
- 700C
- height 30 mm
- front 24 hole / rear 28 hole
- for clinchers

Spokes:

- black
- with aluminium nipples

max. riders weight **110 kg**

Tested by the manufacturer based on ISO 4210

DISC



882 g



1162 g

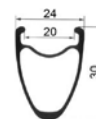

Cyclo Cross	Sprint	Endurance	Aero / Time Trial
-------------	--------	-----------	-------------------

384203 ›30 DISC◀

UVP 499,00 €

Naben:

- Centerlock-Bremsscheibenaufnahme vorne:
- für 12 mm Steckachse
- 2 austauschbare Industriekugellager
- Einbaumaß: 12 x 100 mm
- hinten:
- 4 in 1: vorbereitet für 12 x 142 mm
- 5 austauschbare Industriekugellager
- für 8/9/10/11-fach Shimano Kasette (MTB+Road)
- Einbaumaß: 12 x 142 mm

›30 DISC ◀

Hubs:

- center lock - disc brake mount front:
- for 12 mm thru axle
- 2 exchangeable sealed bearings
- OLD: 12 x 100 mm
- rear:
- 4 in 1: prepared for 12 x 142 mm
- 5 exchangeable sealed bearings
- for 8/9/10/11-speed Shimano cassette (MTB+Road)
- OLD: 12 x 142 mm



GREAT VALUE

384159 ›30 U.1.1◀

UVP 449,00 €

Naben:

- inkl. Schnellspanner
- mit Industriekugellager
- vorne:
- Novatec Nabe A 141 SB
- 20 Loch
- hinten:
- Novatec Nabe F 422 SB
- für 8/9/10/11-fach für Shimano Kasette (MTB+Road)
- 24 Loch

›30 U.1.1◀

Hubs:

- incl. QR
- with sealed bearing
- front:
- Novatec hub A 141 SB
- 20 hole
- rear:
- Novatec hub F 422 SB
- for 8/9/10/11 speed for Shimano cassette (MTB + road)
- 24 hole



820 g



1.080 g

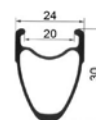

Cyclo Cross	Sprint	Endurance	Aero / Time Trial
-------------	--------	-----------	-------------------

CONVERSION KITS

Front hubs	5 mm	9 mm	12 mm	15 mm	20 mm	Rear hubs	5 x 135 mm	10 x 135 mm	12 x 135 mm	12 x 142 mm
Diablo	320094			320293	325897	Diablo	320095			320096
Diablo XL					320123	Flowtrail	320095			320096
Flowtrail	320094			320293	325897	Alpine	320095			320096
Alpine	320094			320293	325897	Dragon	320095			320096
Dragon	320094			320293	325897	Demon				
Demon	320094			320293	325897	CXD 4.0	320112	320079	320080	320081
CXD 4.0	320117	320118	320119	320120		Jetfly Disc 4.0	320112	320079	320080	320081
Jetfly Disc 4.0	320117	320118	320119	320120		R3 Disc 3.0	320112	320079	320080	320081
R3 Disc 3.0	320290		320107							

384142 LAUFRADSATZ ›FLOWTRAIL U2.1‹

UVP 699,00 €

Naben:

- Aluminium-Dichtungsscheiben
- **Bremsscheibenaufnahme vorne:**

- 2 austauschbare, japanische Industriekugellager
- Einbaumaß: 15 x 100 mm

hinten:

- 4 austauschbare, japanische Industriekugellager
- für 8/9/10/(11 MTB)-fach Shimano Kasette
- **schwarz eloxierter** Kassettenkörper mit **Anti Bite Guard** (Art. 326296), umrüstbar auf Sram XD Drive durch Kassettenkörper Art. 326286
- Einbaumaß: 12 x 142 mm

Felgen:

- 29"
- Parabolic-Rim-Design für optimale Kraftverteilung
- **Aluminium-Hohlkammerfelgen**
- **Tubeless ready**, mit **Tubelessventil**
- 32 Loch

Speichen:

- **Nirosta doppelkonifiziert**

Extras:

- inkl. Ersatzspeichen, Ersatznippel, Felgenband
- max. Fahrergewicht **110 kg**

WHEEL SET ›FLOWTRAIL U2.1‹

Hubs:

- aluminium side caps
- **disc brake mount front:**

- 2 exchangeable, Japanese sealed bearings
- OLD: 15 x 100 mm

rear:

- 4 exchangeable, Japanese sealed bearings
- for 8/9/10/(11 MTB) speed Shimano cassette
- **black anodized** cassette body with **Anti Bite Guard** (art. 326296), convertible to Sram XD Drive cassette body art. 326286
- OLD: 12 x 142 mm

Rims:

- 29"
- parabolic rim design for optimal force distribution
- **aluminium** double wall
- **tubeless ready**, with **tubeless valve**
- 32 hole

Spokes:

- **double butted stainless steel**

Extras:

- incl. replacement spokes, nipples, rim tape
- max. riders weight **110 kg**

Tested by the manufacturer based on ISO 4210

BOOST



755 g



900 g

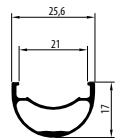

Crosscountry	Trail / Tour	All Mountain	Enduro	Freeride	Downhill
--------------	--------------	--------------	--------	----------	----------

384162 LAUFRADSATZ ›ALPINE U1‹

UVP 699,00 €

Naben:

- Aluminium-Dichtungsscheiben
- **Bremsscheibenaufnahme vorne:**

- 2 austauschbare, japanische Industriekugellager
- Einbaumaß: 15 x 100 mm

hinten:

- 4 austauschbare, japanische Industriekugellager
- für 8/9/10/(11 MTB)-fach Shimano-Kasette
- **schwarz eloxierter** Kassettenkörper mit **Anti Bite Guard** (Art. 326296), umrüstbar auf Sram XD Drive durch Kassettenkörper Art. 326286
- Einbaumaß: 12 x 142 mm

Felgen:

- 29"
- Parabolic-Rim-Design für optimale Kraftverteilung
- **Aluminium-Hohlkammerfelgen**
- **Tubeless ready**, mit **Tubelessventil**
- 32 Loch

Speichen:

- **Nirosta doppelkonifiziert**

Extras:

- inkl. Ersatzspeichen, Ersatznippel, Felgenband
- max. Fahrergewicht **90 kg**

WHEEL SET ›ALPINE U1‹

Hubs:

- aluminium side caps
- **disc brake mount front:**

- 2 exchangeable, Japanese sealed bearings
- OLD: 15 x 100 mm

rear:

- 4 exchangeable, Japanese sealed bearings
- for 8/9/10/(11 MTB) speed Shimano cassette
- **black anodized** cassette body with **Anti Bite Guard** (art. 326296), convertible to Sram XD Drive cassette body art. 326286
- OLD: 12 x 142 mm

Rims:

- 29"
- parabolic rim design for optimal force distribution
- **aluminium** double wall
- **tubeless ready**, with **tubeless valve**
- 32 hole

Spokes:

- **double butted stainless steel**

Extras:

- incl. replacement spokes, nipples, rim tape
- max. riders weight **90 kg**

Tested by the manufacturer based on ISO 4210

BOOST



845 g



989 g

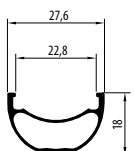

Crosscountry	Trail / Tour	All Mountain	Enduro	Freeride	Downhill
--------------	--------------	--------------	--------	----------	----------

384166 LAUFRADSATZ ›DIABLO‹

UVP 699,00 €

Naben:

- **Bremsscheibenaufnahme**
 - **Aluminium-Dichtungsscheiben**
- vorne:**
- **4 in 1 Nabe** serienmäßig mit 15 mm Steckachse (Umrüstset auf 5 mm bzw. 9 mm QR oder 20 mm Steckachse optional erhältlich)
 - **2 austauschbare, japanische Industriekugellager**

hinten:

- **4 in 1 Nabe** serienmäßig mit X12 Steckachse (Umrüstset auf 5 mm bzw. 10 mm QR oder 12 mm Festachse optional erhältlich)
- **4 austauschbare, japanische Industriekugellager**
- für 8-11-fach Shimano Kassette (MTB)
- **schwarz eloxierter** Kassettenkörper mit **Anti Bite Guard** (Art. 326296)
- umrüstbar auf Sram XD Drive durch Kassettenkörper Art. 326286
- Einbaumaß: 142 mm

Felgen:

- **27,5"/650B**
- **Aluminium-Hohlkammerfelge** mit Ösen
- **Tubeless ready**
- 32 Loch

Speichen:

- **Nirosta doppelkonifiziert**
max. Fahrergewicht 90 kg

WHEEL SET ›DIABLO‹

Hubs:

- **disc brake mount**
 - **aluminium** side caps
- front:**
- **4 in 1 hub** standard with 15 mm thru axle (conversion kit for 5 mm or 9 mm QR or 20 mm thru axle optionally available)
 - **2 exchangeable, Japanese sealed bearings**

rear:

- **4 in 1 hub** standard with X12 thru axle (conversion kit for 5 mm or 10 mm QR or 12 mm solid axle optionally available)
- **4 exchangeable, Japanese sealed bearings**
- für 8-11 speed Shimano cassette (MTB)
- **black anodized** cassette body with **Anti Bite Guard** (art. 326296)
- convertible to Sram XD Drive by cassette body art. 326286
- OLD: 142 mm

Rims:

- **27,5"/650B**
- **aluminium** double wall rim with eyelets
- **tubeless ready**
- 32 hole

Spokes:

- **double butted stainless steel**
max. riders weight 90 kg

Tested by the manufacturer based on ISO 4210

4 in 1



830 g



1.030 g

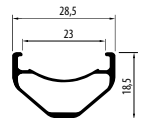

Crosscountry	Trail / Tour	All Mountain	Enduro	Freeride	Downhill
--------------	--------------	--------------	--------	----------	----------

384144 LAUFRADSATZ ›DEMON‹

UVP 799,00 €

Naben

- **Bremsscheibenaufnahme**
 - **Aluminium-Dichtungsscheiben**
- vorne:**
- **4 in 1 Scheibenbremsnabe** serienmäßig für 20 mm Steckachse. Umrüstkit für 5 mm, 10 mm, 15 mm (Art. 320293) optional auf Anfrage
 - 2 austauschbare, japanische Industriekugellager
 - Einbaumaß: 110 mm

hinten:

- **Scheibenbremsnabe** serienmäßig für 12 mm Steckachse (optional erweiterbar auf X12)
- 4 austauschbare, japanische Industriekugellager
- für 8-11-fach Shimano Kassette (MTB)
- **schwarz eloxierter** Kassettenkörper mit **Anti Bite Guard** (Art. 326296)
- umrüstbar auf Sram XD Drive durch Kassettenkörper Art. 326286
- Einbaumaß: 157 mm

Felgen:

- Parabolic-Rim-Design für optimale Kraftverteilung
- **breite Plus-Felge mit 26/32 mm**
- **Tubeless ready**
- **650B+/27,5+**
- Aluminium-Hohlkammerfelge mit Ösen
- Verbindungsstelle verschweißt
- 32 Loch

Speichen:

- **Nirosta doppelkonifiziert**
- **Extras:**
- inkl. Ersatzspeichen
- inkl. Ersatznippel
- max. Fahrergewicht **90 kg**

WHEEL SET ›DEMON‹

Hubs:

- **disc brake mount**
 - **aluminium** side caps
- front:**
- **4 in 1 disc brake hub** standard for 20 mm thru axle. Conversion kit for 5 mm, 10 mm, 15 mm (art. 320293) optionally on request
 - 2 exchangeable, Japanese sealed bearings
 - OLD: 110 mm

rear:

- **disc brake hub** standard for 12 mm thru axle (optionally expandable to X12)
- 4 exchangeable, Japanese sealed bearings
- für 8-11 speed Shimano cassette (MTB)
- **black anodized** cassette body with **Anti Bite Guard** (art. 326296)
- convertible to Sram XD Drive by cassette body art. 326286
- OLD: 157 mm

Rims:

- parabolic rim design for optimal force distribution
- **wide Plus rim with 26/32 mm**
- **tubeless ready**
- **650B+/27,5+**
- aluminium double wall rim with eyelets
- welded rim joint
- 32 hole

Spokes:

- **double butted stainless steel**
- **Extras:**
- incl. replacement spokes
- incl. replacement nipples
- max. riders weight **90 kg**

Tested by the manufacturer based on ISO 4210

4 in 1

650 B+



905 g



1.125 g

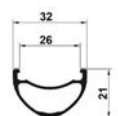

Crosscountry	Trail / Tour	All Mountain	Enduro	Freeride	Downhill
--------------	--------------	--------------	--------	----------	----------





NOVATEC

QUALITY • PERFORMANCE • RELIABILITY

LEICHT WIE EINE FEDER - STARK WIE EIN OCHSE LIGHT AS A FEATHER - STRONG AS AN OX

Leicht, zuverlässig, innovativ. Qualitativ hochwertig, ansprechender Look, ein attraktiver Preis. Die Wahrnehmung von Novatec im Markt könnte nicht besser sein. Und das wissen auch zahlreiche renommierte Erstausrüster zu schätzen, für die Novatec Naben produziert.

Lightweight, reliable and innovative. High quality, appealing look and attractive price. The perception of Novatec could not be better in the market. Numerous renowned original equipment manufacturer – for which Novatec hubs are produced – will appreciate this.



DIE REFERENZNABEN MIT BOOST-STANDARD THE REFERENCE HUBS WITH BOOST STANDARD

Die Hinterradnabe XDS642SB (Art. 326502) besticht durch ihren formschönen Straightpull-Aluminiumkörper. Nicht weniger als 42 Rasterpunkten stehen den sechs starken Doppel-Sperrklinken zur Verfügung. Damit wird auch die minimalste Bewegung in maximalen Vortrieb verwandelt. Gewohnt hohes Niveau mit Anti-Bite-Guard und vier großen Premium-Lagern. Alles im Boost-Standard. Die XDS641SB (Art. 326500) unterstreicht ihre Führungsposition insbesondere durch ihre Laufruhe, und das auch bei härtesten Einsätzen.

The rear hub XDS642SB (art. 326502) impresses with its shapely straight pull aluminum body. No less than forty-two grid points are available to the six strong double pawls. This turns even the most minimal movement into maximum propulsion. The usual high level with anti-bite guard and four large premium bearings. Everything in the boost standard. The XDS641SB (art. 326500) underscores its leadership position with its smoothness, even in the toughest applications.

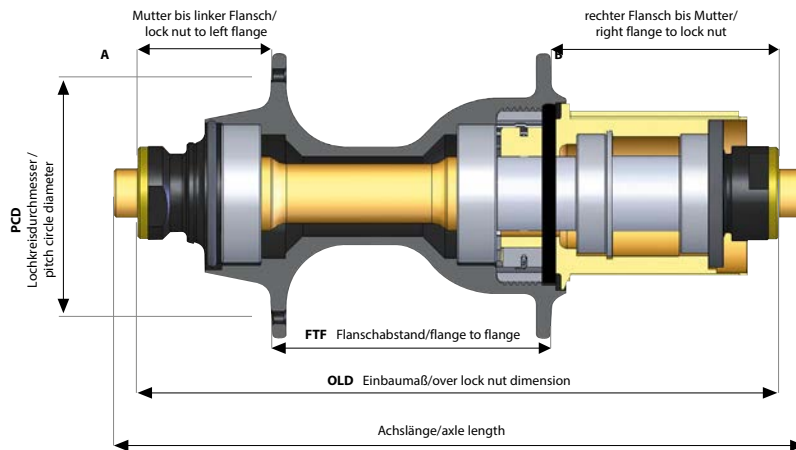

ULTRALIGHT

CARBON

ULTRALIGHT

VORDERRADSCHWIBENBREMSNABE ›D411CB‹

- **UD-Carbon Straight Pull**-Scheibenbremsnabe
- **2 japanische Industriekugellager**
- **4 in 1:** serienmäßig vorbereitet für 15 mm Steckachse, Umrüstset für Schnellspanner 5 mm (Art. 320290), 9 mm und 12 mm (Art. 320107) optional erhältlich
- vom Hersteller empfohlen für Rennrad und Cyclocross
- nur **79 g**
- Einbaumaß: 100 mm
- PCD 34 mm, FTF 63,6 mm, Offset: 3,2 mm
- im Novatec Einzelkarton

326378 28 Loch
326391 24 Loch

FRONT DISC BRAKE HUB ›D411CB‹

- **UD carbon straight pull** disc brake hub
- **2 Japanese sealed bearings**
- **4 in 1:** standard fitted for 15 mm thru axle, conversion kit for QR 5 mm (art. 320290), 9 mm and 12 mm (art. 320107) optionally available
- recommended by the manufacturer for roadbike und cyclocross
- only **79 g**
- OLD: 100 mm
- PCD 34 mm, FTF 63.6 mm, Offset: 3.2 mm
- in Novatec box

28 hole
 24 hole

4 IN 1



UVP 129,90 €

320290 Ausgleichshülsen für 5 mm Schnellspanner

spacers for 5 mm quick release

320107 Ausgleichshülsen für 12 mm Schnellspanner

spacers for 12 mm quick release

UVP 11,90 €



HINTERRADSCHWIBENBREMSNABE ›D412CB‹

- **UD-Carbon Straight Pull**-Scheibenbremsnabe
- **4 Industriekugellager**
- **4 in 1:** serienmäßig vorbereitet für 12 x 142 mm-Steckachse, Umrüstset für Schnellspanner 5 mm (Art. 320291), 10 x 135 mm, 12 x 135 mm optional erhältlich
- für 10- und 11-fach (Shimano Road und MTB)
- umrüstbar auf Sram XD Drive durch Kassettenskörper Art. 326293 und für 12-fach Sram-Kassetten durch XD und XDR Drive Kassettenskörper Art. 326272
- nur **229 g**
- Einbaumaß: 142 mm
- PCD 34/47 mm, FTF 68 mm, Offset: 6,3 mm
- im Novatec Einzelkarton

326379 28 Loch
326392 24 Loch

REAR DISC BRAKE HUB ›D412CB‹

- **UD carbon straight pull** disc brake hub
- **4 sealed bearings**
- **4 in 1:** standard fitted for 12 x 142 mm thru axle, conversion kit for QR 5 mm (art. 320291), 10 x 135 mm, 12 x 135 mm optionally available
- for 10 and 11 speed (Shimano Road and MTB)
- convertible to Sram XD Drive by cassette body art. 326293 and for 12 speed Sram cassettes by XD and XDR Drive cassette body art. 326272
- only **229 g**
- OLD: 142 mm
- PCD 34/47 mm, FTF 68 mm, Offset: 6.3 mm
- in Novatec box

28 hole
 24 hole

4 IN 1



UVP 174,90 €

320291 Umrüstset für 5 x 135 mm Schnellspanner

conversion kit for 5 x 135 mm quick release

UVP 19,90 €



SUPERLIGHT FRONT SUPERLIGHT

**VORDERRADSCHWINGEN-
BREMSNABE ›D791SB/A‹**

- 32 Loch
- **4 in 1:** ausgestattet mit **5 mm Aluminium Schnellspanner**, optional umrüstbar durch Ausgleichshülsen für 9 mm (Art. 320118) Schnellspanner, 12 mm (Art. 320119) und 15 mm (Art. 320120) Steckachse
- **2 japanische Industriekugellager**
- Aluminium-Achse
- nur **157 g** (ohne Schnellspanner)
- Einbaumaß: 100 mm
- PCD: 58/45 mm, FTF: 62 mm
- A: 26,2 mm, B: 11,8 mm
- im Novatec Einzelkarton

326420 schwarz eloxiert

326423 rot eloxiert

UVP 74,90 €

FRONT

**FRONT DISC BRAKE HUB
›D791SB/A‹**

- 32 hole
- **4 in 1:** equipped with **5 mm aluminium quick release**, optionally convertible through spacers to 9 mm (art. 320118) QR, 12 mm (art. 320119) and 15 mm (art. 320120) thru axle
- **2 Japanese sealed bearings**
- aluminium axle
- only **157 g** (w/o quick release)
- OLD: 100 mm
- PCD: 58/45 mm, FTF: 62 mm
- A: 26.2 mm, B: 11.8 mm
- in Novatec box

black anodised

red anodised

4 IN 1



326417

- **32 Loch**
- **4 in 1:** vorbereitet für **15 mm Steckachse**, optional umrüstbar durch Ausgleichshülsen auf 5 mm (Art. 320117), 9 mm (Art.320118) Schnellspanner und 12 mm (Art. 320119) Steckachse
- nur **141 g** (ohne Steckachse)

UVP 64,90 €

- **32 hole**
- **4 in 1:** prepared for **15 mm thru axle**, optionally convertible through spacers to 5 mm (art. 320117), 9 mm (art. 320118) QR and 12 mm (art. 320119) thru axle
- only **141 g** (w/o thru axle)



326416

- **24 Loch**
- **4 in 1:** vorbereitet für **12 mm Steckachse**, optional umrüstbar durch Ausgleichshülsen für 5 mm (Art. 320117) oder 9 mm (Art. 320118) Schnellspanner und 15 mm (Art. 320120) Steckachse
- nur **141 g** (ohne Steckachse)

UVP 64,90 €

- **24 hole**
- **4 in 1:** prepared for **12 mm thru axle**, optionally convertible through spacers to 5 mm (art. 320117) or 9 mm (art. 320118) QR and 15 mm thru axle (art. 320120)
- only **141 g** (w/o thru axle)



326448

- **28 Loch**
- **4 in 1:** vorbereitet für **12 mm Steckachse**, optional umrüstbar durch Ausgleichshülsen für 5 mm (Art. 320280) oder 9 mm Schnellspanner und für 15 mm Steckachse
- für **Centerlock** Bremsscheiben
- nur **141 g** (ohne Steckachse)

UVP 64,90 €

- **28 hole**
- **4 in 1:** prepared for **12 mm thru axle**, optionally convertible through spacers to 5 mm (art. 320280) or 9 mm QR and to 15 mm thru axle
- for **centerlock** brake discs
- only **141 g** (w/o thru axle)

CENTERLOCK



Ausgleichshülsen für Nabenmodell D791SB

spacers for hub type D791SB

320117 für 5 mm Schnellspanner

for 5 mm quick release

320118 für 9 mm Schnellspanner

for 9 mm quick release

320119 für 12 mm Schnellspanner

for 12 mm quick release

320120 für 15 mm Steckachse

for 15 mm thru axle

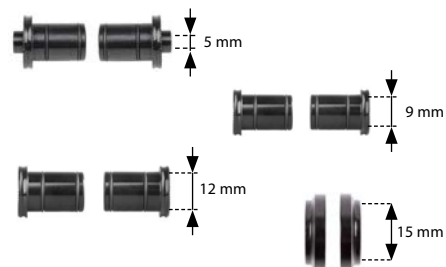

UVP 11,90 €

SUPERLIGHT

REAR

SUPERLIGHT

HINTERRADSCHLEIBENBREMSNABE ›D792SB/A-AA‹

- 32 Loch
- **4 in 1:** ausgestattet mit 5 mm Aluminium-Schnellspanner, optional umrüstbar durch Umrüstsets für 10 mm (Art. 320079), 12 mm (Art. 320080) und X12 Steckachse (Art. 320081)
- **4 japanische Industriekugellager**
- Aluminium-Achse
- kompatibel mit Shimano 8-11fach (MTB+Road)
- umrüstbar auf Sram XD Drive durch Kassettenkörper Art. 326293 und für 12-fach Sram-Kassetten durch XD und XDR Drive Kassettenkörper Art. 326272
- nur **269 g** (ohne Schnellspanner)
- Einbaumaß: 135 mm
- PCD: 58/49 mm, FTF: 56,4 mm
- A: 31,5 mm, B: 47,1 mm
- im Novatec Einzelkarton

326450 schwarz eloxiert

326453 rot eloxiert

UVP 129,90 €

REAR DISC BRAKE HUB ›D792SB/A-AA‹

- 32 hole
- **4 in 1:** equipped with aluminium quick release (5 mm), optionally convertible through spacers to 10 mm thru axle (art. 320079), 12 mm thru axle (art. 320080) and X12 thru axle (art. 320081)
- **4 Japanese sealed bearings**
- aluminium axle
- compatible with Shimano 8-11speed (MTB+Road)
- convertible to Sram XD Drive by cassette body art. 326293 and for 12 speed Sram cassettes by XD and XDR Drive cassette body art. 326272
- only **269 g** (w/o quick release)
- OLD: 135 mm
- PCD: 58/49 mm, FTF: 56.4 mm
- A: 31.5 mm, B: 47.1 mm
- in Novatec box

black anodised

red anodised

4 IN 1



- **4 in 1:** vorbereitet für **12 x 142 mm Steckachse**, optional umrüstbar durch Ausgleichshülsen auf 5 mm Schnellspanner (Art. 320112) und 10 mm Steckachse (Art. 320079) sowie 12x135 mm Steckachse (Art. 320080)
- Einbaumaß: 142 mm

Kassettenfreilaufkörper passend für Shimano 8-11fach (MTB + Road)

326460 32 Loch

326473 24 Loch

326449 • 28 Loch

UVP 129,90 €

- für **Centerlock** Bremsscheiben
- optional umrüstbar durch Ausgleichshülsen auf 5 mm Schnellspanner (Art. 320282)

- **4 in 1:** prepared for **12 x 142 mm thru axle**, optionally convertible through spacers to 5 mm quick release (art. 320112) and 10 mm thru axle (art. 320079) as well as 12x135 mm thru axle (art. 320080)
- OLD: 142 mm

cassette body suitable for Shimano 8-11speed (MTB+Road)

32 hole

24 hole

• 28 hole

- for **centerlock** brake discs
- optionally convertible through spacers to 5 mm quick release (art. 320282)



CENTERLOCK



326463 • 32 Loch

UVP 119,90 €

- Kassettenfreilaufkörper passend für **Sram**, mit XD Drive, silber

• 32 hole

- cassette body suitable for **Sram**, with XD Drive, silver

Umrüstsets für Nabenmodell D792SB

spacers for hub type D792SB

320112 Umrüstset, CrMo, für 5 mm Schnellspanner

UVP 19,90 €

conversion kit, CrMo, for 5 mm QR

320079 Umrüstset, CrMo, für 10 mm Steckachse, mit Schnellspanner

UVP 29,90 €

conversion kit, CrMo, for 10 mm thru axle, with QR

320080 Umrüstset, CrMo, für 12 mm Steckachse, Einbaumaß: 135 mm

UVP 19,90 €

conversion kit, CrMo, for 12 mm thru axle, OLD: 135 mm

320081 Umrüstset, CrMo, für X12 Steckachse, Einbaumaß: 142 mm

UVP 19,90 €

conversion kit, CrMo, for X12 thru axle, OLD: 142 mm

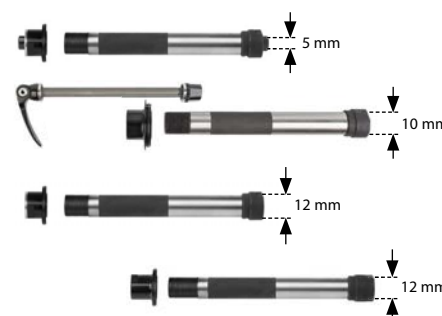

ENDURO/ROAD

ENDURO/ROAD

325123 VORDERRADSCHIBEN-BREMSNABE ›D811SB-15‹

UVP 54,90 €

- 32 Loch
- für **15 mm Steckachse**
- **2 Industriekugellager**
- nur 173 g
- Einbaumaß: 100 mm
- PCD: 58/45 mm, FTF: 62 mm
A: 26,2 mm, B: 11,8 mm
- im Novatec Einzelkarton

FRONT DISC BRAKE HUB ›D811SB-15‹

- 32 hole
- for **15 mm thru axle**
- **2 sealed bearings**
- only 173 g
- OLD: 100 mm
- PCD: 58/45 mm, FTF: 62 mm
A: 26.2 mm, B: 11.8 mm
- in Novatec box

Ø 15 MM



321443 HINTERRADSCHIBENBREMS-NABE ›D982TSB-X12-11S‹

UVP 59,90 €

- 32 Loch
- für **12 mm Steckachse**
- **2 Industriekugellager**
- für 8-11(MTB)-fach Shimano Kassette
- Einbaumaß: **142 mm**
- PCD: 58/49 mm, FTF: 63,1 mm
A: 35,4 mm, B: 49,3 mm
- Montageverpackung

REAR DISC BRAKE HUB ›D982TSB-X12-11S‹

- 32 hole
- for **12 mm thru axle**
- **2 sealed bearings**
- for 8-11(MTB) speed Shimano cassette
- OLD: **142 mm**
- PCD: 58/49 mm, FTF: 63.1 mm
A: 35.4 mm, B: 49.3 mm
- OEM

Ø 12 MM



BOOST

BOOST

326500 VORDERRADSCHIBEN-BREMSNABE ›XDS641SB-B15‹

UVP 109,90 €

- **Boost**
- Aluminium **Straight Pull**
- **28 Loch**
- für **15 mm Steckachse**
- 2 Industriekugellager
- Gewicht: 170 g
- Einbaumaß: **110 mm**
- PCD: 37 mm, FTF: 77,5 mm
Offset: 6,5 mm
- Montageverpackung

FRONT DISC BRAKE HUB ›XDS641SB-B15‹

- **Boost**
- aluminium **Straight Pull**
- **28 hole**
- for **15 mm thru axle**
- 2 sealed bearings
- weight: 170 g
- OLD: **110 mm**
- PCD: 37 mm, FTF: 77.5 mm
Offset: 6.5 mm
- OEM

OLD 110

2 IN 1



326502 HINTERRADSCHIBENBREMS-NABE ›XDS642SB-B12-ABG‹

UVP 209,90 €

- **Boost**
- Aluminium **Straight Pull**
- **28 Loch**
- für **12 mm Steckachse**
- **5 Industriekugellager**
- für 8-11 (MTB)-fach Shimano
- nur 337 g
- Kassettenfreilaufkörper mit **6 Sperrklinken, Anti-Bite-Guard** und Ratchet Ring mit 42 Zähnen für schnelle Kraftübertragung fast **ohne Verzögerung**
- umrüstbar auf Sram XD Drive durch Kassettenfreilaufkörper Art. 326286
- Einbaumaß: **148 mm**
- Montageverpackung

REAR DISC BRAKE HUB ›XDS642SB-B12-ABG‹

- **Boost**
- aluminium **Straight Pull**
- **28 hole**
- for **12 mm thru axle**
- **5 sealed bearings**
- for 8-11(MTB) speed Shimano
- only 337 g
- cassette body with **6 pawls, anti-bite-guard** and ratchet ring with 42 teeth for fast power transmission nearly **without delay**
- convertible to Sram XD Drive through cassette body art. 326286
- OLD: **148 mm**
- OEM

OLD 148



BOOST

BOOST

326137 VORDERRADSCHLEIBEN-BREMSNABE ›D791SB-B15‹

UVP 55,90 €

- **Boost**
- 32 Loch
- für **15 mm Steckachse**
- 2 Industriekugellager
- nur 146 g
- Einbaumaß: **110 mm**
- PCD: 58/45 mm, FTF: 72 mm
A: 26,7 mm, B: 12,3 mm
- im Novatec Einzelkarton

FRONT DISC BRAKE HUB ›D791SB-B15‹

- **Boost**
- 32 hole
- for **15 mm thru axle**
- 2 sealed bearings
- only 146 g
- **OLD: 110 mm**
- PCD: 58/45 mm, FTF: 72 mm
A: 26.7 mm, B: 12.3 mm
- in Novatec box

OLD 110

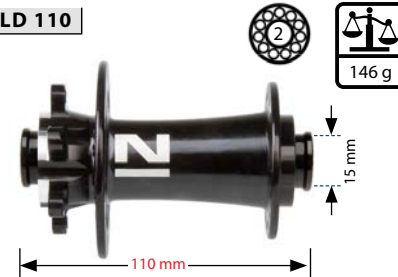

326572 HINTERRADSCHLEIBEN-BREMSNABE ›D932SB-B12-S66S-11S‹

UVP 224,90 €



- **verstärkte Nabe** um den erhöhten Anforderungen von **E-Bikes** zu entsprechen
- für **12 mm Steckachse**
- 32 Loch
- mit **4 Industriekugellagern**
- kompatibel mit Shimano 8-11fach (MTB + Road)
- Kassettenfreilaufkörper mit **2 x 6 Sperrklinken** und Ratchet Ring mit **48 Zähnen** für schnelle Kraftübertragung fast **ohne Verzögerung**
- Einbaumaß: **148 mm**
- PCD: 62 mm, FTF: 61,6 mm
A: 35,6 mm, B: 50,8 mm
- im Novatec Einzelkarton

REAR DISC BRAKE HUB ›D932SB-B12-S66S-11S‹

- **reinforced hub** to conform to the increased demands of **e-bikes**
- for **12 mm thru axle**
- 32 hole
- with **4 sealed bearings**
- compatible with Shimano 8-11speed (MTB+Road)
- cassette body with **2 x 6 pawls** and ratchet ring with **48 teeth** for fast power transmission nearly **without delay**
- **OLD: 148 mm**
- PCD: 62 mm, FTF: 61.6 mm
A: 35.6 mm, B: 50.8 mm
- in Novatec box

OLD 148

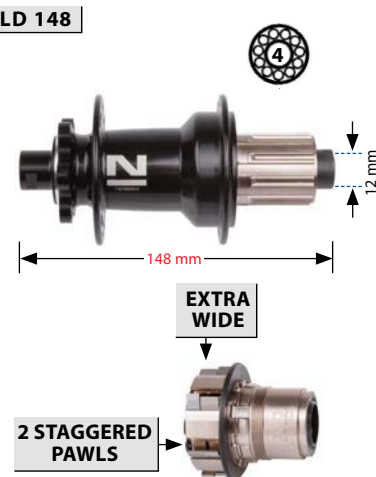

Tested by the manufacturer based on E-Bike Norm DIN EN 15194

326127 HINTERRADSCHLEIBEN-BREMSNABE ›D462SB-B12‹

- **Boost**
- 32 Loch
- für **12 mm Steckachse**
- **5 Industriekugellager**
- Kassettenfreilaufkörper mit **3 Sperrklinken** und Ratchet Ring mit 33 Zähnen für schnelle Kraftübertragung fast **ohne Verzögerung**
- nur 325 g
- umrüstbar auf **Microspline** Kassettenkörper Art. 326268
- umrüstbar auf Sram XD Drive durch Kassettenfreilaufkörper Art. 326031
- Einbaumaß: **148 mm**
- PCD: 62/58 mm, FTF: 62,5 mm
A: 35,2 mm, B: 50,3 mm
- im Novatec Einzelkarton

REAR DISC BRAKE HUB ›D462SB-B12‹

- **Boost**
- 32 hole
- for **12 mm thru axle**
- **5 sealed bearings**
- cassette body with **3 pawls** and ratchet ring with 33 teeth for fast power transmission nearly **without delay**
- only 325 g
- conversion kit to **Microspline** cassette body art. 326268
- convertible to Sram XD Drive through cassette body art. 326031
- **OLD: 148 mm**
- PCD: 62/58 mm, FTF: 62.5 mm
A: 35.2 mm, B: 50.3 mm
- in Novatec box



326140 mit Microspline Kassettenkörper Art. 326268



- im Novatec Einzelkarton

- with **Microspline** cassette body art. 326268
- in Novatec box

326184 verstärkte Nabe um den erhöhten Anforderungen von E-Bikes zu entsprechen

UVP 99,90 €



- 463 g
- Montageverpackung

- **reinforced hub** to conform to the increased demands of **e-bikes**
- for 8-11 (MTB) speed Shimano
- 463 g
- OEM



BOOST

BOOST

• **326435 HINTERRADSCHIBEN-
BREMSNABE ›D442SB-B12-MS‹**
UVP 64,90 €

- **Boost**
- 32 Loch
- für **12 mm Steckachse**
- **4 Industriekugellager**
- mit **Microspline** Kassettenkörper
- Einbaumaß: **148 mm**
- PCD: 58 mm, FTF: 62,9 mm
A: 35,2 mm, B: 49,9 mm
- Montageverpackung

**REAR DISC BRAKE HUB
›D442SB-B12-MS‹**

- **Boost**
- 32 hole
- for **12 mm thru axle**
- **4 sealed bearings**
- with **microspline** cassette body
- OLD: **148 mm**
- PCD: 58 mm, FTF: 62.9 mm
A: 35.2 mm, B: 49.9 mm
- OEM



DOWNHILL

DOWNHILL

**326330 VORDERRADSCHIBEN-
BREMSNABE ›DH61SB-HL‹**
UVP 59,90 €

- **2 Industriekugellager**
- für **20 mm Steckachse**
- 179 g
- 32 Loch
- Einbaumaß: **110 mm**
PCD: 58/45 mm, FTF: 60,4 mm
A: 30,8 mm, B: 19 mm
- im Novatec Einzelkarton

**FRONT DISC BRAKE HUB
›DH61SB-HL‹**

- **2 sealed bearings**
- for **20 mm thru axle**
- 179 g
- 32 hole
- OLD: **110 mm**
PCD: 58/45 mm, FTF: 60.4 mm
A: 30.8 mm, B: 19 mm
- in Novatec box



**326151 HINTERRADSCHIBEN-
BREMSNABE ›DH82SB/A-SS‹**
UVP 119,90 €

- **4 japanische Industriekugellager**
- für **12 mm Festachse**
- 390 g
- 32 Loch
- für 8/9/10/11 (MTB)-fach Shimano
- Einbaumaß: **150 mm**
PCD: 58/49 mm, FTF: 74,45 mm
A: 31 mm, B: 45 mm
- im Novatec Einzelkarton

**REAR DISC BRAKE HUB
›DH82SB/A-SS‹**

- **4 Japanese sealed bearings**
- for **12 mm solid axle**
- 390 g
- 32 hole
- for 8/9/10/11 (MTB) speed Shimano
- OLD: **150 mm**
PCD: 58/49 mm, FTF: 74.45 mm
A: 31 mm, B: 45 mm
- in Novatec box



FAT TIRE

FAT TIRE

326148 VORDERRADSCHWINGEN- BREMSNABE ›D101SB‹

UVP 69,90 €

- für Fat Tire Bikes
- 36 Loch
- **3 in 1**: ausgestattet mit 5 mm Aluminium-Schnellspanner, optional umrüstbar für 9 mm und 15 mm
- **2 Industriekugellager**
- schwarz
- nur 208 g (ohne Schnellspanner)
- **Einbaumaß: 135 mm**
- PCD: 58 mm, FTF: 72 mm
A: 28 mm, B: 28 mm
- Montageverpackung

FRONT DISC BRAKE HUB ›D101SB‹

- for Fat Tire Bikes
- 36 hole
- **3 in 1**: equipped with aluminium quick release 5 mm, optionally convertible for 9 mm and 15 mm
- **2 sealed bearings**
- black
- only 208 g (w/o quick release)
- **OLD: 135 mm**
- PCD: 58 mm, FTF: 72 mm
A: 28 mm, B: 28 mm
- OEM

3 IN 1



326149 HINTERRADSCHWINGEN- BREMSNABE ›D102SB/SS‹

UVP 99,90 €

- für Fat Tire Bikes
- 36 Loch
- **4 in 1**: ausgestattet mit 10 mm Aluminium-Schnellspanner, optional umrüstbar für 5 mm, 12 mm und X12
- **5 Industriekugellager**
- schwarz
- für 8-11 (MTB)-fach Shimano
- nur 418 g (ohne Schnellspanner)
- **Einbaumaß: 170 mm**
- PCD: 58 mm, FTF: 78 mm
A: 46 mm, B: 46 mm
- Montageverpackung

REAR DISC BRAKE HUB ›D102SB/SS‹

- for Fat Tire Bikes
- 36 hole
- **4 in 1**: equipped with aluminium quick release 10 mm, optionally convertible for 5 mm, 12 mm and X12
- **5 sealed bearings**
- black
- for 8-11 (MTB) speed Shimano
- only 418 g (w/o quick release)
- **OLD: 170 mm**
- PCD: 58 mm, FTF: 78 mm
A: 46 mm, B: 46 mm
- OEM

4 IN 1



326132 VORDERRADSCHWINGEN- BREMSNABE ›D201SB‹

UVP 84,90 €

- für Fat Tire Bikes
- 32 Loch
- **3 in 1**: ausgestattet für 15 mm Steckachse, optional umrüstbar für 5 mm und 9 mm
- **2 Industriekugellager**
- nur 207 g
- **Einbaumaß: 150 mm**
- PCD: 58 mm, FTF: 90,6 mm
- Montageverpackung

FRONT DISC BRAKE HUB ›D201SB‹

- for Fat Tire Bikes
- 32 hole
- **3 in 1**: equipped for 15 mm thru axle, optionally convertible for 5 mm and 9 mm
- **2 sealed bearings**
- only 207 g
- **OLD: 150 mm**
- PCD: 58 mm, FTF: 90.6 mm
- OEM

3 IN 1



326134 HINTERRADSCHWINGEN- BREMSNABE ›D202/SS‹

UVP 134,90 €

- für Fat Tire Bikes
- 32 Loch
- **4 in 1**: ausgestattet für 12 x 197 mm Steckachse (für X-12 Schnellspanner), optional umrüstbar für 5 mm (Art. 320292), 10 mm und 12 x 190 mm
- **5 Industriekugellager**
- für 8-11 (MTB)-fach Shimano
- **Einbaumaß: 197 mm**
- PCD: 58 mm, FTF: 98 mm
A: 49,2 mm, B: 52,5 mm
- Montageverpackung

REAR DISC BRAKE HUB ›D202/SS‹

- for Fat Tire Bikes
- 32 hole
- **4 in 1**: equipped for 12 x 197 mm thru axle (for QR X-12), optionally convertible for 5 mm (art. 320292), 10 mm and 12 x 190 mm
- **5 sealed bearings**
- for 8-11 (MTB) speed Shimano
- **OLD: 197 mm**
- PCD: 58 mm, FTF: 98 mm
- OEM

4 IN 1



320292 Umrüstset für 5 x 190 mm Schnellspanner

UVP 32,90 €

conversion kit for QR 5 x 190 mm



SEALED

SEALED

**VORDERRADSCHIEBEN-
BREMSNABE ›D041SB‹**

- mit **2 Industriekugellagern**
- 216 g (ohne Schnellspanner)
- Einbaumaß: 100 mm
- PCD: 58 mm, FTF: 62 mm
A: 26,2 mm, B: 11,8 mm
- Montageverpackung

326220 36 Loch

326222 32 Loch

UVP 39,90 €

**FRONT DISC BRAKE HUB
›D041SB‹**

- with **2 sealed bearings**
- 216 g (w/o quick release)
- OLD: 100 mm
- PCD: 58 mm, FTF: 62 mm
A: 26.2 mm, B: 11.8 mm
- OEM

36 hole

32 hole



**HINTERRADSCHIEBEN-
BREMSNABE ›D042SB‹**

- mit **4 Industriekugellagern**
- 492 g (ohne Schnellspanner)
- für 8-11-fach MTB und 8-10-fach Road Shimano Kassette
- Einbaumaß: 135 mm
- PCD: 58 mm, FTF: 58,4 mm
A: 31,5 mm, B: 45,1 mm
- Montageverpackung

326221 36 Loch

326223 32 Loch

UVP 64,90 €

**REAR DISC BRAKE HUB
›D042SB‹**

- with **4 sealed bearings**
- 492 g (w/o quick release)
- for 8-11 speed MTB and 8-10 speed road Shimano cassette
- OLD: 135 mm
- PCD: 58 mm, FTF: 58.4 mm
A: 31.5 mm, B: 45.1 mm
- OEM

36 hole

32 hole



SUPERLIGHT

SUPERLIGHT

VORDERRADNABE ›A291SB‹

- mit **2 Industriekugellagern**
- mit **abnehmbarem** Schnellspannhebel
- Speichenlöcher auch passend für Aero-Speichen (bis 2,5 mm)
- Einbaumaß: 100 mm
- PCD: 30 mm, FTF: 68,7 mm
A: 15,6 mm, B: 15,6 mm
- im Novatec Einzelkarton

325268 32 Loch, **76 g** (ohne Schnellspanner)
325353 28 Loch, Montageverpackung
325210 20 Loch

UVP 44,90 €

FRONT HUB ›A291SB‹

- with **2 sealed bearings**
- with **removable** quick release lever
- holes also suitable for Aero spokes (up to 2.5 mm)
- OLD: 100 mm
- PCD: 30 mm, FTF: 68.7 mm
A: 15.6 mm, B: 15.6 mm
- in Novatec box

32 hole, **76 g** (w/o quick release)
28 hole, OEM
20 hole



HINTERRADNABE ›F482SB/AA-11S‹

- mit **4 Industriekugellagern**
- Aluminium-Kassettenfreilaufkörper für **8-11-fach** Shimano Kassetten (MTB + Road)
- umrüstbar für Campagnolo-Zahnkranz mit Kassettenfreilaufkörper Art. 325706
- **235 g** (ohne Schnellspanner)
- Speichenlöcher auch passend für Aero-Speichen (bis 2,5 mm)
- Einbaumaß: 130 mm
- PCD: 41/49 mm, FTF: 57 mm
A: 27,2 mm, B: 47,4 mm
- im Novatec Einzelkarton

326080 32 Loch
326081 24 Loch

UVP 89,90 €

REAR HUB ›F482SB/AA-11S‹

- with **4 sealed bearings**
- aluminium cassette body
- for **8-11** speed Shimano cassette (MTB + road)
- convertible for Campagnolo sprocket with cassette body art. 325706
- **235 g** (w/o quick release)
- holes also suitable for Aero spokes (up to 2.5 mm)
- OLD: 130 mm
- PCD: 41/49 mm, FTF: 57 mm
A: 27.2 mm, B: 47.4 mm
- in Novatec box

32 hole
24 hole



LIGHT + SEALED + NICE PRICE

LIGHT+ SEALED + NICE PRICE

VORDERRADNABE ›A141SB‹

- mit **2 austauschbaren Industriekugellagern**
- **118 g** (ohne Schnellspanner)
- Einbaumaß: 100 mm
- PCD: 38 mm, FTF: 72 mm
A: 14 mm, B: 14 mm
- Montageverpackung

325156 36 Loch
325157 32 Loch

UVP 22,90 €

FRONT HUB ›A141SB‹

- with **2 replaceable sealed bearings**
- **118 g** (w/o quick release)
- OLD: 100 mm
- PCD: 38 mm, FTF: 72 mm
A: 14 mm, B: 14 mm
- OEM

36 hole
32 hole



HINTERRADNABE ›F162SB/AA-11S‹

- mit **4 Industriekugellagern**
- **276 g** (ohne Schnellspanner)
- für 8-11-fach Road + MTB Shimano Kassetten mit **3 Sperrklinken**
- umrüstbar auf Campagnolo Art. 325283
- Einbaumaß: 135 mm
- PCD: 49 mm, FTF: 57,3 mm
A: 31,25, B: 46,45
- Montageverpackung

325158 36 Loch
325159 32 Loch

UVP 54,90 €

REAR HUB ›F162SB/AA-11S‹

- with **4 sealed bearings**
- **276 g** (w/o quick release)
- for 8-11 speed road + MTB Shimano cassette with **3 pawls**
- convertible to Campagnolo art. 325283
- OLD: 135 mm
- PCD: 49 mm, FTF: 57.3 mm
A: 31.25, B: 46.45
- OEM

36 hole
32 hole



VORDERRADNABE ›A565SBT‹

- für Vorderrad Hochflansch
- mit 2 **Industriekugellagern**
- **CrMo**-Achse M9 x 140 mm
- Einbaumaß: 100 mm
- PCD: 62 mm, FTF: 70 mm
- A: 15 mm, B: 15 mm
- Montageverpackung

326700 • **36 Loch**
UVP 36,90 € • silber

326701 • **32 Loch**
UVP 37,90 € • schwarz eloxiert

FRONT HUB ›A565SBT‹

- front high flange
- with 2 **sealed bearings**
- **CrMo** axle M9 x 140 mm
- OLD: 100 mm
- PCD: 62 mm, FTF: 70 mm
- A: 15 mm, B: 15 mm
- OEM

• **36 hole**
• silver

• **32 hole**
• black anodised



HINTERRADNABE ›A566SBT‹

- für Hinterrad Hochflansch
- 32 Loch
- mit 2 **Industriekugellagern**
- **CrMo**-Achse M10 x 165 mm
- Einbaumaß: 120 mm
- PCD: 62 mm, FTF: 59 mm
- A: 30,5 mm, B: 30,5 mm
- Montageverpackung

Gewinde 1,37" und 1,29" **beidseitig**

326702 • 36 Loch
• silber

326703 • 32 Loch
• schwarz eloxiert

UVP 49,90 €

REAR HUB ›A566SBT‹

- rear high flange
- 32 hole
- with 2 **sealed bearings**
- **CrMo** axle M10 x 165 mm
- OLD: 120 mm
- PCD: 62 mm, FTF: 59 mm
- A: 30.5 mm, B: 30.5 mm
- OEM

thread 1.37" and 1.29" on **both sides**

• 36 hole
• silver

• 32 hole
• black anodised



326704 • **free/ fixed**
• Gewinde 1,37" und 1,37/1,29"
• schwarz eloxiert

UVP 49,90 €

• **free/ fixed**
• thread 1.37" and 1.37/1.29"
• black anodised

NABENZUBEHÖR / HUB ACCESSORIES

BAHN/SINGLE SPEED- NABENZUBEHÖR

329907 Mutter für **VR**-Bahn-Naben
UVP 1,90 € (Art. 325710, ...)

329908 Mutter für **Hinterrad**-Bahn-Naben
UVP 1,90 € (Art. 325711, ...)

329909 Zahnkranzverschlussring für
UVP 2,90 € Hinterrad-Naben (Art. 325711, ...)

TRACK/SINGLE SPEED HUB ACCESSORIES

nut for **front** track hubs
(art. 325710, ...)

nut for **rear** track hubs
(art. 325711, ...)

lock ring for rear hubs
(art. 325711, ...)

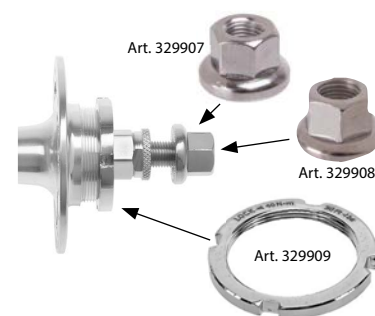

ZAHNKRANZ 1/2 X 1/8"

325797 13 Zähne
325591 14 Zähne
325592 15 Zähne
325593 16 Zähne
325604 17 Zähne
325594 18 Zähne

UVP 5,90 €

SPROCKET 1/2 X 1/8"

13 teeth
14 teeth
15 teeth
16 teeth
17 teeth
18 teeth



STECKACHSE MIT HEBEL

- Aluminium
- Ausrichtung des Hebels auch in geschlossenem Zustand änderbar
- im Polybeutel mit Novatec Euroloch-header

›QR269F‹

- 321086**
- Einbaumaß 12 x 100 mm
 - M12 x Länge 118,5 mm
 - Gewindesteigung 1,5 mm
 - Gewindelänge 10,5 mm
 - passend für z. B. Art. 391570

- 321097**
- Einbaumaß 15 x 100 mm
 - M15 x Länge 148 mm
 - Gewindesteigung 1,5 mm
 - Gewindelänge 10 mm
 - passend für z. B. Art. 395040 und diverse Rockshox Gabeln

- 321096**
- ›QR269R‹
- Einbaumaß 142 mm (X12)
 - M12 x Länge 166 mm
 - Gewindesteigung 1,5 mm
 - Gewindelänge 10 mm
 - passend für z. B. Art. 661510, ...

- 321070**
- ›QR264 SYNTACE‹
- Einbaumaß 142 mm (X12)
 - M12 x Länge 163 mm
 - Gewindesteigung 1 mm
 - Gewindelänge 20 mm
 - für Syntace, DT, Novatec, ... Art. 321440, ... (kein original Syntace, DT Ersatzteil)

- 321071**
- ›QR264 SHIMANO‹
- UVP 36,90 €
- Einbaumaß 142 mm (X12)
 - M12 x Länge 172 mm
 - Gewindesteigung 1,5 mm
 - Gewindelänge 18 mm
 - für Shimano-X12 (kein original Shimano Ersatzteil)
 - z. B. für 661940, 661953 ff, ...

Steckachse mit anderem Durchmesser, Länge, ... auf Anfrage erhältlich

THRU AXLE WITH LEVER

- aluminium
- adjustable position of lever even when closed
- in PE bag with Novatec eurohole header

›QR269F‹

- OLD 12 x 100 mm
- M12 x length 118.5 mm
- thread pitch: 1.5 mm
- thread length: 10.5 mm
- suitable for e. g. art. 391570

- OLD 15 x 100 mm
- M15 x length 148 mm
- thread pitch: 1.5 mm
- thread length: 10 mm
- suitable for e. g. art. 395040 and other Rockshox forks

- ›QR269R‹
- OLD 142 mm (X12)
 - M12 x length 166 mm
 - thread pitch: 1.5 mm
 - thread length: 10 mm
 - suitable for e. g. art. 661510, ...

- ›QR264 SYNTACE‹
- OLD 142 mm (X12)
 - M12 x length 163 mm
 - thread pitch: 1 mm
 - thread length: 20 mm
 - for Syntace, DT, Novatec, ... art. 321440, ... (no original Syntace, DT spare part)

- ›QR264 SHIMANO‹
- OLD 142 mm (X12)
 - M12 x length 172 mm
 - thread pitch: 1.5 mm
 - thread length: 18 mm
 - for Shimano-X12 (no original Shimano spare part)
 - e. g. for 661940, 661953 et seq., ...

Thru axle with other diameter, length, ... available on request



SCHNELLSPANNER

- Aluminium
- schwarz eloxiert
- Montageverpackung

- 321122**
- für Vorderradnabe
 - Einbaumaß: 100 mm
 - nur **39 g**

- 321123**
- für Hinterradnabe
 - Einbaumaß: 135 mm
 - nur **45 g**

UVP 6,90 €

QUICK RELEASE

- aluminium
- black anodised
- OEM

- for front hub
- OLD: 100 mm
- only **39 g**

- for rear hub
- OLD 135 mm
- only **45 g**



- 321060**
- UVP 12,90 €
- Set aus Schnellspannern für Vorderradnabe (Art. 321122) und für Hinterradnabe (Art. 321123)
- nur **84 g/Set**
 - auf Novatec Eurolochkarte

- Set of quick releases for front hub (art. 321122) and for rear hub (art. 321123)
- only **84 g/set**
 - on Novatec eurohole card

KASSETTENFREILAUFKÖRPER

im Novatec Einzelkarton

CASSETTE BODY

in Novatec Box

INFO

Welcher Kassettenfreilaufkörper passt zu meiner Nabe? - Siehe Seite 26.

Which cassette body fits to my hub? - Just have a look on page 26.

SHIMANO TYP

SHIMANO TYPE

326283 Typ ›B2‹
 • **Aluminium**
 UVP 54,90 € • für 8-11-fach **Shimano** Kassette (Road + MTB)
 • 4 Sperrklinken
 • mit **Anti-Bite-Guard**

›B2‹ type
 • **aluminium**
 • for 8-11 speed **Shimano** cassette (road + MTB)
 • 4 pawls
 • with **Anti-Bite-Guard**



ANTI-BITE-GUARD

326294 Typ ›B2‹
 • **Aluminium**
 UVP 34,90 € • für 8-11-fach **Shimano** Kassette (Road + MTB)
 • 4 Sperrklinken

›B2‹ type
 • **aluminium**
 • for 8-11 speed **Shimano** cassette (road + MTB)
 • 4 pawls



326274 Typ ›F‹
 • **Aluminium**
 UVP 49,90 € • für 8-10-(Road) + 11 (MTB)-fach **Shimano** Kassette
 • **5 Sperrklinken**

›F‹ type
 • **aluminium**
 • for 8-10 (road) + 11 (MTB) speed **Shimano** cassette
 • **5 pawls**



326292 Typ ›A2‹
 • **Aluminium**
 UVP 34,90 € • für 8-11-fach **Shimano** Kassette (Road + MTB)

›A2‹ type
 • **aluminium**
 • for 8-11 speed **Shimano** cassette (road + MTB)



325725 Typ ›B1‹
 • **Aluminium**
 UVP 34,90 € • für 8-10-(Road) + 11 (MTB)-fach **Shimano** Kassette
 • 4 Sperrklinken

›B1‹ type
 • **aluminium**
 • for 8-10 (road) + 11 (MTB) speed **Shimano** cassette
 • 4 pawls



325285 Typ ›B LS‹
 • für 8-10-(Road) + 11 (MTB)-fach **Shimano** Kassette
 UVP 34,90 €

›B LS‹ type
 • for 8-10 (road) + 11 (MTB) speed **Shimano** cassette



CAMPAGNOLO TYP

CAMPAGNOLO TYPE

325283 Typ ›A‹
 • **Aluminium**
 UVP 39,90 € • für 9-12-fach **Campagnolo** Kassette

›A‹ type
 • **aluminium**
 • for 9-12-speed **Campagnolo** cassette



325706 Typ ›B1‹
 • **Aluminium**
 UVP 39,90 € • für 9-12-fach **Campagnolo** Kassette

›B1‹ type
 • **aluminium**
 • for 9-12-speed **Campagnolo** cassette



326266 Typ ›B1‹
 • **Aluminium**
 UVP 59,90 € • für 13-fach **Campagnolo** Kassette

›B1‹ type
 • **aluminium**
 • for 13-speed **Campagnolo** cassette



SRAM TYP

SRAM TYPE

XD Drive: für (Road + MTB) **Sram**
XG-Kassetten

XD Drive: for (road + MTB) **Sram**
XG cassettes

326282

- Typ ›E‹
- für E-Bike Nabe Art. 326572
 - **12 Sperrklinken**
 - im Novatec Einzelkarton

- ›E‹ type
- for e-bike hub art. 326572
 - **12 pawls**
 - in Novatec box

UVP 89,90 €

326286

- Typ ›X4‹
- **Aluminium**
 - **6 Sperrklinken**
 - im Polybeutel

- ›X4‹ type
- **aluminium**
 - **6 pawls**
 - in PE bag

UVP 79,90 €

326031

- Typ ›F‹
- **3 Sperrklinken**
 - im Novatec Einzelkarton

- ›F‹ type
- **3 pawls**
 - in Novatec box

UVP 49,90 €

326293

- Typ ›B‹
- 4 Sperrklinken
 - im Novatec Einzelkarton

- ›B‹ type
- 4 pawls
 - in Novatec box

UVP 49,90 €



XDR Drive: für 11-/12-fach (Road + MTB)
Sram XG-Kassette

XDR Drive: for 11/12 speed (road + MTB)
Sram XG-cassette

326272

- Typ ›B‹
- **Aluminium**
 - 1,8 mm Adapter (für 11-fach Road)
 - im Novatec Einzelkarton

- ›B‹ type
- **aluminium**
 - 1.8 mm washer (for 11 speed road)
 - in Novatec box

UVP 69,00 €



MICROSPLINE TYP

MICROSPLINE TYPE

326268

- Achse und Kassette
- für Boost-Nabe Art. 326127/40/84
- 3 Sperrklinken
- im Polybeutel

- axle and cassette
- for boost hub art. 326127/40/84
- 3 pawls
- in PE bag

UVP 59,90 €



INFO Welches Umrüstset benötige ich? Which conversion kit do I need?

Vorderradnabe front hub	5 mm	9 mm	12 mm	15 mm	20 mm
D411	320290		320107		
D791	320117	320118	320119	320120	
D791-CL	320281			320098	
XD611-CL	320110	320092	320111	320093	
D541	320094			320293	
D101					
D201	320117	320118	320119	320297	
D881	320094			320293	325897
XD641SB-B15					320123
30 Disc	320117	320118	320119	320120	
Diablo	320094			320293	325897
Diablo XL					320123
Flowtrail	320094			320293	325897
Alpine	320094			320293	325897
Dragon	320094			320293	325897
Demon	320094			320293	325897
CXD 4.0	320117	320118	320119	320120	
Jetfly Disc 4.0	320117	320118	320119	320120	
R3 Disc 3.0/4.0	320290		320107		

Hinterradnabe rear hub	5x135	10x135	12x135	12x142
D412	320291			
D792	320112	320079	320080	320081
D792-CL	326282			
XD612	320112	320079	320080	320081
D542				320069
D102				
D202	320292			325472
Diablo	320095			320096
Flowtrail	320095			320096
Alpine	320095			320096
Dragon	320095			320096
Demon				
CXD 4.0	320112	320079	320080	320081
Jetfly Disc 4.0	320112	320079	320080	320081
R3 Disc 3.0	320112	320079	320080	320081
R3 Disc 4.0	320291			

INFO Welcher Kassettenfreilaufkörper passt zu meiner Nabe/Laufrad?
Which cassette body fits to my hub resp. wheel set?

Art. Nabe/Laufrad art. hub/wheelset	Modell Nabe/Laufrad model hub / wheelset	Body- Type	Shimano	Microspline	Campagnolo	XD Drive (Sram)	XDR Drive
321405	D1425B-X12	S5	326288	-	-	-	-
325158	F1625B-11S	A2	326292	-	325283	-	-
325159	F1625B-11S	A2	326292	-	325283	-	-
325198	D7225B-11S	B2	326294, 326283 with ABG	-	325706	326293	326272
326080	F4825B-11S	B2	326294	-	325706	-	326272
326081	F4825B-11S	B2	326294	-	325706	-	326272
326082	F4825B-11S	B2	326294	-	325706	-	326272
326088	F1725B-11S	A2	326292	-	325283	-	-
326089	F1725B-11S	A2	326292	-	325283	-	-
326101	D0425B	A	325281	-	325283	-	-
326118	D7125B-B12	B1	325725	-	-	326293	326272
326131	D1025B	B	325285	-	-	326293	326272
326134	D2025B	B1	325725	-	-	326293	326272
326151	DH825B	B	325285	-	-	326393	326272
326181	D5425B	X5	-	-	-	-	-
326321	D0425B	A	325281	-	-	-	-
326323	D0425B	A	325281	-	-	-	-
326354	D7725B-11S	B2	326294, 326283 with ABG	-	-	326293	326272
326355	D7725B-11S	B2	326294, 326283 with ABG	-	-	326293	326272
326356	D7725B-11S	B2	326294, 326283 with ABG	-	-	326293	326272
326361	D7725B-11S	B2	326294, 326283 with ABG	-	-	326293	326272
326362	D7725B-11S	B2	326294, 326283 with ABG	-	-	326293	326272
326363	D7725B-11S	B2	326294, 326283 with ABG	-	-	326293	326272
326333	D7725B-11S	B2	326294, 326283 with ABG	-	-	326293	326272
326335	D7725B-11S	B2	326294, 326283 with ABG	-	-	326293	326272
326450	D7925B-11S	B2	326294, 326283 with ABG	-	-	326293	326272
326452	D7925B-11S	B2	326294, 326283 with ABG	-	-	326293	326272
326453	D7925B-11S	B2	326294, 326283 with ABG	-	-	326293	326272
326454	D7925B-11S	B2	326294, 326283 with ABG	-	-	326293	326272
326455	D7925B-11S	B2	326294, 326283 with ABG	-	-	326293	326272
326456	D7925B-11S	B2	326294, 326283 with ABG	-	-	326293	326272
326460	D7925B-11S	B2	326294, 326283 with ABG	-	-	326293	326272
326461	D7925B-11S	B2	326294, 326283 with ABG	-	-	326293	326272
326127	D4625B-B12	F	326274	326268	-	326275	-
321440	D1625B-SL-X12	F (Loose ball)	-	-	-	-	-
326375	FS62CB-11S	B2	326294	-	-	-	326272
326379	D412CB-11S	B2	326294	-	-	326293	326272
326501	DS4625B-A5A-B12	F	326274	-	-	326275	-
326502	XDS6425B-B12-ABG	X4	326296	-	-	326286	-
326572	D9325B-B12	E	-	-	-	326282	-
384126	R5 Clincher	D2	326297	-	326298	-	-
384213	R3 Clincher Disc 4.0	B2	326294, 326283 with ABG	-	-	326293	326272
384128	R3 Clincher Disc 3.0	D2	326297	-	326298	-	-
384144	Demon U2.1	X4	326296	-	-	326286	-
384159	Thirty U1.1	-	-	-	-	-	-
384179	Jetfly Disc 4.0	B2	326294, 326283 with ABG	-	-	326293	326272
384181	CXD 4.0	B2	326294, 326283 with ABG	-	-	326293	326272
384182	Jetfly SL U1.1	D2	326297	-	326298	-	-
384184	Thirty Disc 1.1	-	-	-	-	-	-
384236	Flowtrail 2.1 - Boost	X4	326296	-	-	326286	-
384237	Flowtrail 2.1 - Boost	X4	326296	-	-	326286	-
384238	Alpine U2.1 - Boost	X4	326296	-	-	326286	-
384239	Alpine U2.1 - Boost	X4	326296	-	-	326286	-
384240	Diablo XL U2.1 - Boost	X4	326296	-	-	326286	-
384175	SPRINT	D2	326297	326298	-	-	-
384176	JETFLY	D2	326297	326298	-	-	-
384177	CXD	D2	326297	326298	-	-	-
384141	Diablo XL	X4	326296	-	326286	-	-

ERSATZKUGELLAGER

Industriekugellager, zum Beispiel für

- Novatec Naben, linker/rechter Flansch
- Novatec Kassettenfreilaufkörper

REPLACEMENT BEARINGS

sealed bearings, for example for

- Novatec hubs, left and right flange
- Novatec cassette body

Art. 327011
ind. spec. 6902
Innen/Außen-Ø 15/28 mm



Art. 327012
ind. spec. 6000
Innen/Außen-Ø 10/26 mm



Art. 327013
ind. spec. 6901
Innen/Außen-Ø 12/24 mm



Art. 327014
ind. spec. 6001
Innen/Außen-Ø 12/28 mm



Art. 327015
ind. spec. 699
Innen/Außen-Ø 9/20 mm



Art. 327016
ind. spec. 6804
Innen/Außen-Ø 20/32 mm



Art. 327017
ind. spec. 609R5
Innen/Außen-Ø 9/24 mm



Art. 327018
ind. spec. 6802
Innen/Außen-Ø 12/24 mm



Art. 327019
ind. spec. 15267
Innen/Außen-Ø 15/26 mm



Model	left flange	art.	right flange	art.	cassette body
A Type Campy					2 x 327013
A Type Shimano					2 x 327013
B Type Shimano					2 x 327011
B1 Campy					2 x 327018
B1 Shimano					2 x 327011
B2 Type					2 x 327011
A2 Type					2 x 327013
F Type Shimano					2 x 327019, 1 x 327011
F Type Sram					3 x 327019
A141SB	609RS x 1	327017	609RS x 1	327017	X
A165SBT	6000 x 1	327012	6000 x 1	327012	X
A166SBT	6000 x 1	327012	6000 x 1	327012	X
A171SB	609RS x 1	327017	609RS x 1	327017	X
A291SB	699 x 1	327015	699 x 1	327015	X
A565SBT	6000 x 1	327012	6000 x 1	327012	X
A566SBT	6000 x 1	327012	6000 x 1	327012	X
AS61CB	699 x 1	327015	699 x 1	327015	X
D032SB	6001 x 1	327014	6001 x 1	327014	2 x 327014
D041SB	6001 x 1	327014	6001 x 1	327014	X
D042SB	6001 x 1	327014	6001 x 1	327014	2 x 327014
D101SB	6902 x 1	327011	6902 x 1	327011	2 x 327011
D102SB	6902 x 1	327011	6902 x 1	327011	2 x 327011
D142SB-X12	6902 x 1	327011			1 x 327019
D162SB-SL-X12	6902 x 1	327011	6902 x 1	327011	only change complete cassette-body
D201SB	6902 x 1	327011	6902 x 1	327011	X
D202SB	6902 x 1	327011	6902 x 1	327011	2 x 327011
D252SB	6001 x 1	327014	6001 x 1	327014	2 x 327014
D411CB	6803 x 1		6803 x 1		X
D412CB	15267 x 1	327019	15267 x 1	327019	2 x 327019
D462SB	6902 x 1	327011	6902 x 1	327011	3 x 327019
D462SB-B12	6902 x 1	327011	6902 x 1	327011	3 x 327019
D541SB	6804 x 1	327016	6804 x 1	327016	X
D542SB	6902 x 1	327011	6809 x 1		2 x 327011
D711SB	6902 x 1	327011	6902 x 1	327011	X
D712SB	6902 x 1	327011	6902 x 1	327011	2 x 327011
D712SB/S45-B12	6902 x 1	327011	6902 x 1	327011	2 x 327011
D722SB	6902 x 1	327011	6902 x 1	327011	2 x 327011
D771SB	6902 x 1	327011	6902 x 1	327011	X
D772SB	6902 x 1	327011	6902 x 1	327011	2 x 327011
D791SB	6902 x 1	327011	6902 x 1	327011	X
D791SB-B12	6902 x 1	327011	6902 x 1	327011	X
D792SB	6902 x 1	327011	6902 x 1	327011	2 x 327011
D811SB-15	6902 x 1	327011	6902 x 1	327011	X
D881SB	6804 x 1	327016	6804 x 1	327016	X
D882SB	6902 x 1	327011	6902 x 1	327011	2 x 327011
D932SB-B12	6902 x 1	327011	6902 x 1	327011	2 x 327018
DH61SB	6804 x 1	327016	6804 x 1	327016	X
DH82SB	6902 x 1	327011	6902 x 1	327011	2 x 327011
F162SB	6001 x 1	327014	6001 x 1	327014	2 x 327013
F172SB	6901 x 1	327013	6001 x 1	327014	2 x 327013
F482SB	6802 x 1	327018	6902 x 1	327011	2 x 327011
FS62CB	6802 x 1	327018	15267 x 1	327019	2 x 327019
XDS641SB-B15	6804 x 1	327016	6804 x 1	327016	X
XDS642SB-B12-ABG	6903 x 1	327021	6903 x 1	327021	2 x #17287

311878 passend für Exustar Pedale Art. 311855/
848/803, Maße: außen 12,94 mm, innen
5,67 mm, Dicke 4,97 mm

suitable for Exustar pedals art. 311855/
848/803, size: outside 12.94 mm, inside
5.67 mm, width 4.97 mm



ind. spec. 686ZZ
Innen/Außen-Ø 5,67/12,94 mm



messingschlager

Haßbergstr. 45
96148 Baunach - Germany
Tel.: +49 (0) 95 44 94 44 - 0
www.novatec.messingschlager.com

Vertrieb / distribution: