



N

NOVATEC[®]

QUALITY • PERFORMANCE • RELIABILITY



READY TO RACE

Leicht, schnell und steif. Sicher, robust und komfortabel. Die Anforderungen, die an Laufräder gestellt werden sind enorm.

Novatec schafft den Spagat und bietet durch die Bank Laufräder, die ein hochattraktives Verhältnis von Preis und Leistung anbieten. Als Technologieführer ist es selbstverständlich, dass Novatec seine eigene Topmodellnabe verbaut. Spitzensportler aus den unterschiedlichsten Disziplinen setzen seit Jahren auf die Laufräder von Novatec.

Light, fast and stiff. Safe, robust and comfortable. The requirements on wheels which are demanded are enormous.

Novatec can build the bridge and offers different wheels, which have an attractive price-performance ratio. It goes without saying that technology leader Novatec installs their own top-of-the-range hubs. Top athletes participating in different disciplines have been counting on wheels of Novatec for years.



R3 DISC

Langdistanz im Dauersprint! Mit 38 mm hohen Carbon-Felgen gleitet der Allrounder über die Straßen und macht selbst im tiefen Sand eine herausragende Figur. Das asymmetrische Felgengedesign verspricht die perfekte Kraftaufnahme der Scheibenbremse und des Antritts auf der Antriebsseite. Die Felgen sind Tubeless-Ready und kommen gänzlich ohne Felgenband aus. Das Herzstück, die Nabe, setzt auf den bewährten Anti Bite-Guard und vier Lager höchster Güte. Felgen und Naben werden mit Straightpull-Aero Speichen in konzentrierter Handarbeit verbunden. Einzigartig ist, dass jedes einzelne Laufrad mit einem Einspeich-Protokoll diese Qualität belegt.

Long distance in a permanent sprint! With 38 mm high carbon rims, the all-rounder floats along the streets and makes an outstanding figure even in deep sand. The asymmetric rim design promises the perfect power absorption of the disc brake and the acceleration on the drive side. The rims are tubeless-ready and are completely without rim tape. The heart, the hub, relies on the proven anti-bite guard and four bearings of the highest quality. Rims and hubs are combined with straight pull aero spokes in concentrated manual work. What is unique is that every single wheel with a spoking protocol proves this quality.

384125 LAUFRADSATZ ›R9 U3.0‹

UVP 1.799,00 €



Naben:

- mit **Titan**-Schnellspannern
- **Aluminium**-Dichtungsscheiben

vorne:

- 2 **austauschbare, japanische Industriekugellager**

hinten:

- 4 **austauschbare, japanische Industriekugellager**
- für 8/9/10/11-fach Kassette für Shimano oder Sram (Road+MTB)
- **rot eloxierter, austauschbarer** Kassettenkörper (Art. 326297 = Shimano/Sram, Art. 326293 = Sram XD, Art. 326298 = Campagnolo), mit **Anti Bite Guard**

Felgen:

- Carbon-Hohlkammerfelge, UD-finish
- für **Draht-/Kevlarreifen**
- **Tubeless ready**
- 700C
- Höhe **90 mm**
- vorne 16 Loch / hinten 20 Loch

Speichen:

- Straight Pull **Aero**-Speichen
- Aluminium Nippel

Extras:

- **inkl. Bremsschuhe**
- **inkl. Ventilverlängerung**
- inkl. Ersatzspeichen
- inkl. Ersatznippel

max. Fahrergewicht **110 kg**

WHEEL SET ›R9 U3.0‹

Hubs:

- with **titanium** QRs
- **aluminium** side caps

front:

- 2 **exchangeable, Japanese sealed bearings**

rear:

- 4 **exchangeable, Japanese sealed bearings**
- for 8/9/10/11-speed Shimano or Sram cassette (Road+MTB)
- **red anodized, replaceable** cassette body (art. 326297 = Shimano/Sram, art. 326293 = Sram XD, art. 326298 = Campagnolo), with **Anti Bite Guard**

Rims:

- carbon double wall, UD finish
- for **clinchers/Kevlar tires**
- **tubeless ready**
- 700C
- height **90 mm**
- front 16 hole / rear 20 hole

Spokes:

- straight pull **aero** spokes
- aluminium nipples

Extras:

- **incl. brake shoes**
- **incl. valve extender**
- incl. replacement spokes
- incl. replacement nipples

max. riders weight **110 kg**

Tested by the manufacturer based on ISO 4210

TUBELESS READY



1.940 g



880 g



1.060 g



| | | | |
|-----------|--------|-----------|-------------------|
| Gravel/CX | Sprint | Endurance | Aero / Time Trial |
|-----------|--------|-----------|-------------------|

384126 LAUFRADSATZ ›R5 U3.0‹

UVP 1.763,00 €



Naben:

- mit **Titan**-Schnellspannern
- **Aluminium**-Dichtungsscheiben

vorne:

- 2 **austauschbare, japanische Industriekugellager**

hinten:

- 4 **austauschbare, japanische Industriekugellager**
- für 8/9/10/11-fach Kassette für Shimano oder Sram (Road+MTB)
- **rot eloxierter, austauschbarer** Kassettenkörper (Art. 326297 = Shimano/Sram, Art. 326293 = Sram XD, Art. 326298 = Campagnolo), mit **Anti Bite Guard**

Felgen:

- Carbon-Hohlkammerfelge, UD-finish
- **Tubeless ready**
- 700C
- Höhe **50 mm**
- vorne 20 Loch / hinten 24 Loch
- für Drahtreifen

Speichen:

- Straight Pull **Aero**-Speichen
- Aluminium Nippel

Extras:

- **inkl. Bremsschuhe**
- **inkl. Ventilverlängerung**
- inkl. Ersatzspeichen
- inkl. Ersatznippel

max. Fahrergewicht **110 kg**

WHEEL SET ›R5 U3.0‹

Hubs:

- with **titanium** QRs
- **aluminium** side caps

front:

- 2 **exchangeable, Japanese sealed bearings**

rear:

- 4 **exchangeable, Japanese sealed bearings**
- for 8/9/10/11-speed Shimano or Sram cassette (Road+MTB)
- **red anodized, replaceable** cassette body (art. 326297 = Shimano/Sram, art. 326293 = Sram XD, art. 326298 = Campagnolo), with **Anti Bite Guard**

Rims:

- carbon double wall, UD finish
- **tubeless ready**
- 700C
- height **50 mm**
- front 20 hole / rear 24 hole
- for clinchers

Spokes:

- straight pull **aero** spokes
- aluminium nipples

Extras:

- **incl. brake shoes**
- **incl. valve extender**
- incl. replacement spokes
- incl. replacement nipples

max. riders weight **110 kg**

Tested by the manufacturer based on ISO 4210

UCI APPROVED

TUBELESS READY



1.707 g



758 g



949 g

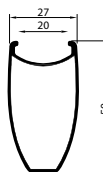

| | | | |
|-----------|--------|-----------|-------------------|
| Gravel/CX | Sprint | Endurance | Aero / Time Trial |
|-----------|--------|-----------|-------------------|

LAUFRADSATZ ›R3‹

Naben:

- Aluminium-Dichtungsscheiben
- vorne:**
- 2 austauschbare, japanische Industriekugellager
- hinten:**
- 4 austauschbare, japanische Industriekugellager

Felgen:

- Carbon-Hohlkammerfelge, UD-finish
- **Tubeless ready**
- 700C
- Höhe **38 mm**
- für Drahtreifen

Speichen:

- Straight Pull **Aero**-Speichen
- schwarze Aluminium-Nippel

max. Fahrergewicht **110 kg**

WHEEL SET ›R3‹

Hubs:

- aluminium side caps
- front:**
- 2 exchangeable, Japanese sealed bearings
- rear:**
- 4 exchangeable, Japanese sealed bearings

Rims:

- carbon double wall, UD finish
- **tubeless ready**
- 700C
- height **38 mm**
- for clinchers

Spokes:

- straight pull **aero** spokes
- black aluminium nipples

max. riders weight **110 kg**

Tested by the manufacturer
based on ISO 4210

TUBELESS READY



665 g



813 g

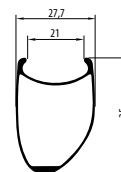

384213 ›R3 CLIN DISC U4.0‹

UVP 1.511,00 €

Naben:

- für **Centerlock** Bremsscheiben
- **UD Carbon**
- **Bremsscheibenaufnahme**
- vorne:**
- Einbaumaß: 12 x 100 mm
- hinten:**
- Einbaumaß: 12 x 142 mm

- **4 in 1:** serienmäßig vorbereitet für 12 x 142 mm-Steckachse, Umrüstset für Schnellspanner 5 mm (Art. 320291), 10 x 135 mm, 12 x 135 mm optional erhältlich

- für 10- und 11-fach (Shimano Road und MTB)
- umrüstbar auf Sram XD Drive durch Kassettenkörper Art. 326293

Felgen:

- **asymmetrisches Felgen-Design** damit Speichen auf Zahnkranzseite weniger steil sind
- vorne 24 Loch / hinten 24 Loch

Extras:

- inkl. Ersatzspeichen
- inkl. Ersatznippel

›R3 CLIN DISC U4.0‹

Hubs:

- for **centerlock** brake discs
- **UD carbon**
- **disc brake mount**
- front:**
- OLD front: 12 x 100 mm
- rear:**
- OLD: 12 x 142 mm
- **4 in 1:** standard fitted for 12 x 142 mm thru axle, conversion kit for QR 5 mm (art. 320291), 10 x 135 mm, 12 x 135 mm optionally available
- for 10 and 11 speed (Shimano Road and MTB)
- convertible to Sram XD Drive by cassette body art. 326293

Rims:

- **asymmetric rim design** so the spokes are not too steep
- front 24 hole / rear 24 hole

Extras:

- incl. replacement spokes
- incl. replacement nipples

| | | | |
|-------------|--------|-----------|-------------------|
| Cyclo Cross | Sprint | Endurance | Aero / Time Trial |
|-------------|--------|-----------|-------------------|

384133 ›R3 U3.0‹

UVP 1.399,00 €

Naben:

- mit **Titan**-Schnellspannern
- Aluminium
- Einbaumaß vorne: 100 mm
- Einbaumaß hinten: 130 mm
- hinten:**

- für 8/9/10/11-fach Kassette für Shimano oder Sram (MTB+Road)
- **rot eloxierter, austauschbarer** Kassettenkörper (Art. 326297 = Shimano/Sram, Art. 326293 = Sram XD, Art. 326298 = Campagnolo), mit **Anti Bite Guard**

Felgen:

- vorne 20 Loch / hinten 24 Loch
- für Felgenbremsen

Extras:

- **inkl. Bremsschuhe**
- inkl. Ersatzspeichen
- inkl. Ersatznippel

›R3 U3.0‹

Hubs:

- with **titanium** QRs
- aluminium
- OLD front: 100 mm
- OLD rear: 130 mm
- rear:**
- for 8/9/10/11-speed Shimano or Sram cassette (MTB+Road)
- **red anodized, replaceable** cassette body (art. 326297 = Shimano/Sram, art. 326293 = Sram XD, art. 326298 = Campagnolo), with **Anti Bite Guard**

Rims:

- front 20 hole / rear 24 hole
- for rim brakes

Extras:

- **incl. brake shoes**
- incl. replacement spokes
- incl. replacement nipples



660 g



840 g

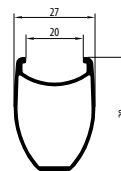

| | | | |
|-------------|--------|-----------|-------------------|
| Cyclo Cross | Sprint | Endurance | Aero / Time Trial |
|-------------|--------|-----------|-------------------|

UCI APPROVED

LAUFRADSATZ 28" ›JETFLY‹

Naben:

- Aluminium-Dichtungsscheiben
- 2/4 austauschbare, japanische Industriekugellager
- für 8/9/10/11-fach Kassette für Shimano oder Sram (MTB+Road)
- rot eloxierter, austauschbarer Aluminium Kassettenkörper (Art. 326297 = Shimano/Sram, Art. 326293 = Sram XD, Art. 326298 = Campagnolo), mit Anti Bite Guard

Felgen:

- Aluminium-Hohlkammerfelge
- **Tubeless ready**
- 700C
- für Drahtreifen

Speichen:

- Nirosta doppelkonifiziert
- Aluminium Nippel

384179 ›JETFLY DISC U4.0‹

UVP 731,00 €

Naben:

- **Bremsscheibenaufnahme vorne:**
- **4 in 1:** vorbereitet für **12 mm Steckachse**, optional umrüstbar durch Ausgleichshülsen für 5 mm (Art. 320117) oder 9 mm (Art. 320118) Schnellspanner und 15 mm (Art. 320120) Steckachse
- Einbaumaß: 12 x 100 mm

hinten:

- **4 in 1:** vorbereitet für **12 mm Steckachse**, optional umrüstbar durch Umrüstsets für 5 mm Schnellspanner (Art. 320112), 10 mm (Art. 320079) und 12x135 mm Steckachse (Art. 320080)
- Einbaumaß: 12 x 142 mm

Felgen:

- **asymmetrisches Felgen-Design**
- Höhe **31,8 mm**
- vorne 24 Loch / hinten 28 Loch

Extras:

inkl. Ersatzspeichen, -nippel und Tubelessventil

max. Fahrergewicht **110 kg**

WHEEL SET 28" ›JETFLY‹

Hubs:

- aluminium side caps
- 2/4 exchangeable, Japanese sealed bearings
- for 8/9/10/11-speed Shimano or Sram cassette (MTB+Road)
- **red anodized, replaceable** aluminium cassette body (art. 326297 = Shimano/Sram, art. 326293 = Sram XD, art. 326298 = Campagnolo), with Anti Bite Guard

Rims:

- aluminium double wall
- **tubeless ready**
- 700C
- for clinchers

Spokes:

- **double butted stainless steel**
- aluminium nipples

›JETFLY DISC U4.0‹

Hubs:

- **disc brake mount front:**
- **4 in 1:** prepared for **12 mm thru axle**, optionally convertible through spacers to 5 mm (art. 320117) or 9 mm (art. 320118) QR and 15 mm thru axle (art. 320120)
- OLD: 12 x 100 mm

rear:

- **4 in 1:** prepared for **12 mm thru axle**, optionally convertible through spacers to 5 mm QR (art. 320112), 10 mm (art. 320079) and 12x135 mm thru axle (art. 320080)
- OLD: 12 x 142 mm

Rims:

- **asymmetric rim design**
- height **31.8 mm**
- front 24 hole / rear 28 hole

Extras:

incl. replacement spokes, nipples and tubeless valve

max. riders weight **110 kg**

Tested by the manufacturer based on ISO 4210

TUBELESS READY



800 g



945 g

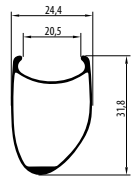

583 g



760 g

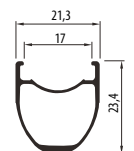

| | | | |
|-----------|--------|-----------|-------------------|
| Gravel/CX | Sprint | Endurance | Aero / Time Trial |
|-----------|--------|-----------|-------------------|

384182 ›JETFLY SL‹

UVP 731,00 €

Naben:

- inkl. Schnellspanner
- Einbaumaß vorne: 5 x 100 mm
- Einbaumaß hinten: 5 x 130 mm

Felgen:

- vorne 20 Loch / hinten 24 Loch
- mit aufgerauten Bremsflanken

Speichen:

- hinten asymmetrisch 8/16 Loch eingespeicht

Extras:

inkl. Ersatzspeichen und -nippel
max. Fahrergewicht **90 kg**

›JETFLY SL‹

Hubs:

- incl. QRs
- OLD front: 5 x 100 mm
- OLD rear: 5 x 130 mm

Rims:

- front 20 hole / rear 24 hole
- grooved braking sides

Spokes:

- rear wheel with asymmetrical 8/16 hole spokes pattern

Extras:

inkl. replacement spokes and nipples
max. riders weight **90 kg**

| | | | |
|-----------|--------|-----------|-------------------|
| Gravel/CX | Sprint | Endurance | Aero / Time Trial |
|-----------|--------|-----------|-------------------|

384181 LAUFRADSATZ 28"

UVP 731,00 €

>CXD U4.0<

Naben:

- **Aluminium**-Dichtungsscheiben
- **Bremsscheibenaufnahme**

vorne:

- **4 in 1:** vorbereitet für **12 mm Steckachse**, optional umrüstbar durch Ausgleichshülsen für 5 mm (Art. 320117) oder 9 mm (Art. 320118) Schnellspanner und 15 mm (Art. 320120) Steckachse
- **2 austauschbare, japanische Industriekugellager**

- Einbaumaß: 12 x 100 mm

hinten:

- **4 in 1:** vorbereitet für **12 mm Steckachse**, optional umrüstbar durch Umrüstsets für 5 mm Schnellspanner (Art. 320112), 10 mm (Art. 320079) und 12x135 mm Steckachse (Art. 320080)
- **4 austauschbare, japanische Industriekugellager**
- Einbaumaß: 12 x 142 mm
- für **8/9/10/11-fach** Shimano oder Sram Kassette (MTB+Road)
- **rot eloxierter, austauschbarer** Aluminium Kassettenkörper (Art. 326297 = Shimano/Sram, Art. 326293 = Sram XD, Art. 326298 = Campagnolo), mit **Anti Bite Guard**

Felgen:

- **asymmetrisches Felgen-Design**
- Aluminium-Hohlkammerfelge
- **Tubeless ready**
- 700C
- Höhe 24 mm
- vorne 20 Loch / hinten 24 Loch
- für Drahtreifen

Speichen:

- **Nirosta doppelkonifiziert**
- mit **schwarzen Aluminium** Nippeln

Extras:

inkl. Ersatzspeichen, -nippel und Tubelessventil

max. Fahrergewicht **110 kg**

WHEEL SET 28"

>CXD U4.0<

Hubs:

- **aluminium** side caps
- **disc brake mount**

front:

- **4 in 1:** prepared for **12 mm thru axle**, optionally convertible through spacers to 5 mm (art. 320117) or 9 mm (art. 320118) QR and 15 mm thru axle (art. 320120)
- **2 exchangeable, Japanese sealed bearings**

- OLD: 12 x 100 mm

rear:

- **4 in 1:** prepared for **12 mm thru axle**, optionally convertible through spacers to 5 mm QR (art. 320112), 10 mm (art. 320079) and 12x135 mm thru axle (art. 320080)
- **4 exchangeable, Japanese sealed bearings**

- OLD: 12 x 142 mm

- for **8/9/10/11-speed** Shimano or Sram cassette (MTB+Road)
- **red anodized, replaceable** aluminium cassette body (art. 326297 = Shimano/Sram, art. 326293 = Sram XD, art. 326298 = Campagnolo), with **Anti Bite Guard**

- **red anodized, replaceable** aluminium cassette body (art. 326297 = Shimano/Sram, art. 326293 = Sram XD, art. 326298 = Campagnolo), with **Anti Bite Guard**

Rims:

- **asymmetric rim design**
- aluminium double wall
- **tubeless ready**
- 700C
- height 24 mm
- front 20 hole / rear 24 hole
- for clinchers

Spokes:

- **double butted stainless steel**
- with **black aluminium** nipples

Extras:

inkl. replacement spokes, nipples and tubeless valve

max. riders weight **110 kg**

Tested by the manufacturer based on ISO 4210

TUBELESS READY

CYCLO CROSS | **DISC**



1.615 g



734 g



881 g

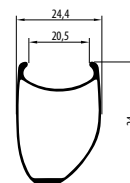

| | | | |
|-----------|--------|-----------|-------------------|
| Gravel/CX | Sprint | Endurance | Aero / Time Trial |
|-----------|--------|-----------|-------------------|



LAUFRADSATZ ›30◀

Felgen:

- Aluminium-Hohlkammerfelge
- Tubeless ready
- 700C
- Höhe 30 mm
- vorne 24 Loch / hinten 28 Loch
- für Drahtreifen

Speichen:

- schwarz
- mit Aluminium Nippeln

max. Fahrergewicht **110 kg**

WHEEL SET ›30◀

Rims:

- aluminium double wall
- tubeless ready
- 700C
- height 30 mm
- front 24 hole / rear 28 hole
- for clinchers

Spokes:

- black
- with aluminium nipples

max. riders weight **110 kg**

Tested by the manufacturer based on ISO 4210

DISC



882 g



1162 g

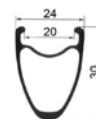

384203 ›30 DISC◀

UVP 475,00 €

Naben:

- Centerlock-Bremsscheibenaufnahme
- vorne:**
 - für 12 mm Steckachse
 - 2 austauschbare Industriekugellager
 - Einbaumaß: 12 x 100 mm
- hinten:**
 - 5 austauschbare Industriekugellager
 - für 8/9/10/11-fach Shimano Kasette (MTB+Road)
 - Einbaumaß: 12 x 142 mm

›30 DISC ◀

Hubs:

- center lock - disc brake mount
- front:**
 - for 12 mm thru axle
 - 2 exchangeable sealed bearings
 - OLD: 12 x 100 mm
- rear:**
 - 5 exchangeable sealed bearings
 - for 8/9/10/11-speed Shimano cassette (MTB+Road)
 - OLD: 12 x 142 mm

| | | | |
|-----------|--------|-----------|-------------------|
| Gravel/CX | Sprint | Endurance | Aero / Time Trial |
|-----------|--------|-----------|-------------------|

GREAT VALUE



820 g



1.080 g

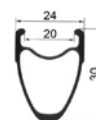

384159 ›30 U.1.1◀

UVP 419,00 €

Naben:

- inkl. Schnellspanner
- mit Industriekugellager
- vorne:**
 - Novatec Nabe A 141 SB
 - 20 Loch
- hinten:**
 - Novatec Nabe F 422 SB
 - für 8/9/10/11-fach für Shimano Kasette (MTB+Road)
 - 24 Loch

›30 U.1.1◀

Hubs:

- incl. QR
- with sealed bearing
- front:**
 - Novatec hub A 141 SB
 - 20 hole
- rear:**
 - Novatec hub F 422 SB
 - for 8/9/10/11 speed for Shimano cassette (MTB + road)
 - 24 hole

| | | | |
|-----------|--------|-----------|-------------------|
| Gravel/CX | Sprint | Endurance | Aero / Time Trial |
|-----------|--------|-----------|-------------------|

CONVERSION KITS

| Front hubs | 5 mm | 9 mm | 12 mm | 15 mm | 20 mm | Rear hubs | 5 x 135 mm | 10 x 135 mm | 12 x 135 mm | 12 x 142 mm |
|-----------------|--------|--------|--------|--------|--------|-----------------|------------|-------------|-------------|-------------|
| Diablo | 320094 | | | 320293 | 325897 | Diablo | 320095 | | | 320096 |
| Diablo XL | | | | | | Flowtrail | 320095 | | | 320096 |
| Flowtrail | 320094 | | | 320293 | 325897 | Alpine | 320095 | | | 320096 |
| Alpine | 320094 | | | 320293 | 325897 | Dragon | 320095 | | | 320096 |
| Dragon | 320094 | | | 320293 | 325897 | Demon | | | | |
| Demon | 320094 | | | 320293 | 325897 | CXD 4.0 | 320112 | 320079 | 320080 | 320081 |
| CXD 4.0 | 320117 | 320118 | 320119 | 320120 | | Jetfly Disc 4.0 | 320112 | 320079 | 320080 | 320081 |
| Jetfly Disc 4.0 | 320117 | 320118 | 320119 | 320120 | | R3 Disc 3.0 | 320112 | 320079 | 320080 | 320081 |
| R3 Disc 3.0 | 320290 | | 320107 | | | | | | | |

384142 LAUFRADSATZ ›FLOWTRAIL U2.1‹

UVP 699,00 €

Naben:

- Aluminium-Dichtungsscheiben

- **Bremsscheibenaufnahme**

vorne:

- 2 austauschbare, japanische Industriekugellager

- Einbaumaß: 15 x 100 mm

hinten:

- 4 austauschbare, japanische Industriekugellager

- für 8/9/10/(11 MTB)-fach Shimano Kassette

- **schwarz eloxierter** Kassettenkörper mit **Anti Bite Guard** (Art. 326296), umrüstbar auf Sram XD-Drive (Art. 326286)

- Einbaumaß: 12 x 142 mm

Felgen:

- 29"

- Parabolic-Rim-Design für optimale Kraftverteilung

- **Aluminium-Hohlkammerfelgen**

- **Tubeless ready**, mit **Tubelessventil**

- 32 Loch

Speichen:

- **Nirosta doppelkonifiziert**

Extras:

- inkl. Ersatzspeichen, Ersatznippel, Felgenband

max. Fahrergewicht **110 kg**

WHEEL SET ›FLOWTRAIL U2.1‹

Hubs:

- aluminium side caps

- **disc brake mount**

front:

- 2 exchangeable, Japanese sealed bearings

- OLD: 15 x 100 mm

rear:

- 4 exchangeable, Japanese sealed bearings

- for 8/9/10/(11 MTB) speed Shimano cassette

- **black anodized** cassette body with **Anti Bite Guard** (art. 326296), convertible to Sram XD-Drive (art. 326286)

- OLD: 12 x 142 mm

Rims:

- 29"

- parabolic rim design for optimal force distribution

- **aluminium** double wall

- **tubeless ready**, with **tubeless valve**

- 32 hole

Spokes:

- **double butted stainless steel**

Extras:

- incl. replacement spokes, nipples, rim tape

max. riders weight **110 kg**

Tested by the manufacturer based on ISO 4210

BOOST



755 g



900 g

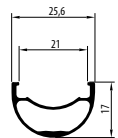

| | | | | | |
|--------------|--------------|--------------|--------|----------|----------|
| Crosscountry | Trail / Tour | All Mountain | Enduro | Freeride | Downhill |
|--------------|--------------|--------------|--------|----------|----------|

384162 LAUFRADSATZ ›ALPINE U1‹

UVP 669,00 €

Naben:

- Aluminium-Dichtungsscheiben

- **Bremsscheibenaufnahme**

vorne:

- 2 austauschbare, japanische Industriekugellager

- Einbaumaß: 15 x 100 mm

hinten:

- 4 austauschbare, japanische Industriekugellager

- für 8/9/10/(11 MTB)-fach Shimano-Kassette

- **schwarz eloxierter** Kassettenkörper mit **Anti Bite Guard** (Art. 326296), umrüstbar auf Sram XD-Drive (Art. 326286)

- Einbaumaß: 12 x 142 mm

Felgen:

- 29"

- Parabolic-Rim-Design für optimale Kraftverteilung

- **Aluminium-Hohlkammerfelgen**

- **Tubeless ready**, mit **Tubelessventil**

- 32 Loch

Speichen:

- **Nirosta doppelkonifiziert**

Extras:

- inkl. Ersatzspeichen, Ersatznippel, Felgenband

max. Fahrergewicht **90 kg**

WHEEL SET ›ALPINE U1‹

Hubs:

- aluminium side caps

- **disc brake mount**

front:

- 2 exchangeable, Japanese sealed bearings

- OLD: 15 x 100 mm

rear:

- 4 exchangeable, Japanese sealed bearings

- for 8/9/10/(11 MTB) speed Shimano cassette

- **black anodized** cassette body with **Anti Bite Guard** (art. 326296), convertible to Sram XD-Drive (art. 326286)

- OLD: 12 x 142 mm

Rims:

- 29"

- parabolic rim design for optimal force distribution

- **aluminium** double wall

- **tubeless ready**, with **tubeless valve**

- 32 hole

Spokes:

- **double butted stainless steel**

Extras:

- incl. replacement spokes, nipples, rim tape

max. riders weight **90 kg**

Tested by the manufacturer based on ISO 4210

BOOST



845 g



989 g

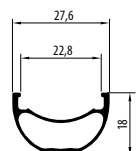

| | | | | | |
|--------------|--------------|--------------|--------|----------|----------|
| Crosscountry | Trail / Tour | All Mountain | Enduro | Freeride | Downhill |
|--------------|--------------|--------------|--------|----------|----------|

384166 LAUFRADSATZ ›DIABLO‹

UVP 659,00 €

Naben:

- **Bremsscheibenaufnahme**
 - **Aluminium-Dichtungsscheiben**
- vorne:**
- **4 in 1 Nabe** serienmäßig mit 15 mm Steckachse (Umrüstset auf 5 mm bzw. 9 mm QR oder 20 mm Steckachse optional erhältlich)
 - **2 austauschbare, japanische Industriekugellager**

hinten:

- **4 in 1 Nabe** serienmäßig mit X12 Steckachse (Umrüstset auf 5 mm bzw. 10 mm QR oder 12 mm Festachse optional erhältlich)
- **4 austauschbare, japanische Industriekugellager**
- für 8-11-fach Shimano Kassette (MTB)
- **schwarz eloxierter** Kassettenkörper mit **Anti Bite Guard** (Art. 326296)
- umrüstbar auf Sram XD Drive durch Kassettenkörper Art. 326286
- Einbaumaß: 142 mm

Felgen:

- **Aluminium-Hohlkammerfelge** mit Ösen
- **Tubeless ready**
- **650B/27,5"**
- 32 Loch

Speichen:

- **Nirosta doppelkonifiziert**

max. Fahrergewicht 90 kg

WHEEL SET ›DIABLO‹

Hubs:

- **disc brake mount**
- **aluminium** side caps

front:

- **4 in 1 hub** standard with 15 mm thru axle (conversion kit for 5 mm or 9 mm QR or 20 mm thru axle optionally available)
- **2 exchangeable, Japanese sealed bearings**

rear:

- **4 in 1 hub** standard with X12 thru axle (conversion kit for 5 mm or 10 mm QR or 12 mm solid axle optionally available)
- **4 exchangeable, Japanese sealed bearings**
- für 8-11 speed Shimano cassette (MTB)
- **black anodized** cassette body with **Anti Bite Guard** (art. 326296)
- convertible to Sram XD Drive by cassette body art. 326286
- OLD: 142 mm

Rims:

- **aluminium** double wall rim with eyelets
- **tubeless ready**
- **650B/27,5"**
- 32 hole

Spokes:

- **double butted stainless steel**

max. riders weight 90 kg

Tested by the manufacturer based on ISO 4210

650 B

4 in 1



830 g



1.030 g

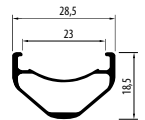

| | | | | | |
|--------------|--------------|--------------|--------|----------|----------|
| Crosscountry | Trail / Tour | All Mountain | Enduro | Freeride | Downhill |
|--------------|--------------|--------------|--------|----------|----------|

384144 LAUFRADSATZ ›DEMON‹

UVP 731,00 €

Naben

- **Bremsscheibenaufnahme**
 - **Aluminium-Dichtungsscheiben**
- vorne:**
- **4 in 1 Scheibenbremsnabe** serienmäßig für 20 mm Steckachse. Umrüstkit für 5 mm, 10 mm, 15 mm (Art. 320293) optional auf Anfrage
 - 2 austauschbare, japanische Industriekugellager
 - Einbaumaß: 110 mm

hinten:

- **Scheibenbremsnabe** serienmäßig für 12 mm Steckachse (optional erweiterbar auf X12)
- 4 austauschbare, japanische Industriekugellager
- für 8-11-fach Shimano Kassette (MTB)
- **schwarz eloxierter** Kassettenkörper mit **Anti Bite Guard** (Art. 326296)
- umrüstbar auf Sram XD Drive durch Kassettenkörper Art. 326286
- Einbaumaß: 157 mm

Felgen:

- Parabolic-Rim-Design für optimale Kraftverteilung
- **breite Plus-Felge mit 26/32 mm**
- **Tubeless ready**
- **650B+/27,5+**
- Aluminium-Hohlkammerfelge mit Ösen
- Verbindungsstelle verschweißt
- 32 Loch

Speichen:

- **Nirosta doppelkonifiziert**

Extras:

- inkl. Ersatzspeichen
- inkl. Ersatznippel

max. Fahrergewicht **90 kg**

WHEEL SET ›DEMON‹

Hubs:

- **disc brake mount**
- **aluminium** side caps

front:

- **4 in 1 disc brake hub** standard for 20 mm thru axle. Conversion kit for 5 mm, 10 mm, 15 mm (art. 320293) optionally on request
- 2 exchangeable, Japanese sealed bearings
- OLD: 110 mm

rear:

- **disc brake hub** standard for 12 mm thru axle (optionally expandable to X12)
- 4 exchangeable, Japanese sealed bearings
- für 8-11 speed Shimano cassette (MTB)
- **black anodized** cassette body with **Anti Bite Guard** (art. 326296)
- convertible to Sram XD Drive by cassette body art. 326286
- OLD: 157 mm

Rims:

- parabolic rim design for optimal force distribution
- **wide Plus rim with 26/32 mm**
- **tubeless ready**
- **650B+/27,5+**
- aluminium double wall rim with eyelets
- welded rim joint
- 32 hole

Spokes:

- **double butted stainless steel**

Extras:

- incl. replacement spokes
- incl. replacement nipples

max. riders weight **90 kg**

Tested by the manufacturer based on ISO 4210

650 B+

4 in 1



905 g



1.125 g

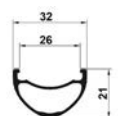

| | | | | | |
|--------------|--------------|--------------|--------|----------|----------|
| Crosscountry | Trail / Tour | All Mountain | Enduro | Freeride | Downhill |
|--------------|--------------|--------------|--------|----------|----------|





NOVATEC

QUALITY • PERFORMANCE • RELIABILITY

LEICHT WIE EINE FEDER - STARK WIE EIN OCHSE LIGHT AS A FEATHER - STRONG AS AN OX

Leicht, zuverlässig, innovativ. Qualitativ hochwertig, ansprechender Look, ein attraktiver Preis. Die Wahrnehmung von Novatec im Markt könnte nicht besser sein. Und das wissen auch zahlreiche renommierte Erstausrüster zu schätzen, für die Novatec Naben produziert.

Lightweight, reliable and innovative. High quality, appealing look and attractive price. The perception of Novatec could not be better in the market. Numerous renowned original equipment manufacturer – for which Novatec hubs are produced – will appreciate this.



DIE REFERENZNABEN MIT BOOST-STANDARD THE REFERENCE HUBS WITH BOOST STANDARD

Die Hinterradnabe XDS642SB (Art. 326502) besticht durch ihren formschönen Straightpull-Aluminiumkörper. Nicht weniger als 42 Rasterpunkte stehen den sechs starken Doppel-Sperrklinken zur Verfügung. Damit wird auch die minimalste Bewegung in maximalen Vortrieb verwandelt. Gewohnt hohes Niveau mit Anti-Bite-Guard und vier großen Premium-Lagern. Alles im Boost-Standard. Die XDS641SB (Art. 326500) unterstreicht ihre Führungsposition insbesondere durch ihre Laufruhe, und das auch bei härtesten Einsätzen.

The rear hub XDS642SB (art. 326502) impresses with its shapely straight pull aluminum body. No less than forty-two grid points are available to the six strong double pawls. This turns even the most minimal movement into maximum propulsion. The usual high level with anti-bite guard and four large premium bearings. Everything in the boost standard. The XDS641SB (art. 326500) underscores its leadership position with its smoothness, even in the toughest applications.

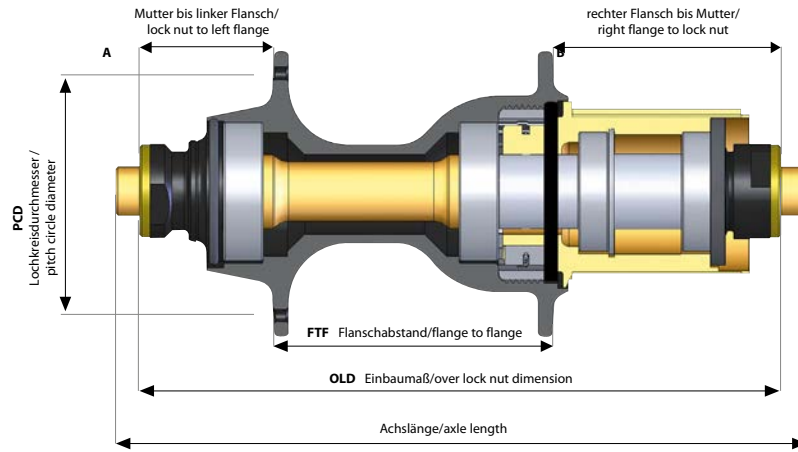

ULTRALIGHT

CARBON

ULTRALIGHT

VORDERRADSCHNABEN- BREMSNABE ›D411CB‹

- **UD-Carbon Straight Pull-** Scheibenbremsnabe
- **2 japanische Industriekugellager**
- **4 in 1:** serienmäßig vorbereitet für 15 mm Steckachse, Umrüstset für Schnellspanner 5 mm (Art. 320290), 9 mm und 12 mm (Art. 320107) optional erhältlich
- vom Hersteller empfohlen für Rennrad und Cyclocross
- nur **79 g**
- Einbaumaß: 100 mm
- PCD 34 mm, FTF 63,6 mm, Offset: 3,2 mm
- im Novatec Einzelkarton

326378 28 Loch

326391 24 Loch

UVP 129,00 €

320290 Ausgleichshülsen für 5 mm Schnellspanner

320107 Ausgleichshülsen für 12 mm Schnellspanner

UVP 11,90 €

HINTERRADSCHNABEN- BREMSNABE ›D412CB‹

- **UD-Carbon Straight Pull-** Scheibenbremsnabe
- **4 Industriekugellager**
- **4 in 1:** serienmäßig vorbereitet für 12 x 142 mm-Steckachse, Umrüstset für Schnellspanner 5 mm (Art. 320291), 10 x 135 mm, 12 x 135 mm optional erhältlich
- für 10- und 11-fach (Shimano Road und MTB)
- umrüstbar auf Sram XD Drive durch Kassettenträger Art. 326293 und für 12-fach Sram-Kassetten durch XD und XDR Drive Kassettenträgerkörper Art. 326272
- nur **229 g**
- Einbaumaß: 142 mm
- PCD 34/47 mm, FTF 68 mm, Offset: 6,3 mm
- im Novatec Einzelkarton

326379 28 Loch

326392 24 Loch

UVP 185,00 €

320291 Umrüstset für 5 x 135 mm Schnellspanner

UVP 19,90 €

FRONT DISC BRAKE HUB ›D411CB‹

- **UD carbon straight pull** disc brake hub
- **2 Japanese sealed bearings**
- **4 in 1:** standard fitted for 15 mm thru axle, conversion kit for QR 5 mm (art. 320290), 9 mm and 12 mm (art. 320107) optionally available
- recommended by the manufacturer for roadbike und cyclocross
- only **79 g**
- OLD: 100 mm
- PCD 34 mm, FTF 63.6 mm, Offset: 3.2 mm
- in Novatec box

28 hole

24 hole

spacers for 5 mm quick release

spacers for 12 mm quick release

4 IN 1



REAR DISC BRAKE HUB ›D412CB‹

- **UD carbon straight pull** disc brake hub
- **4 sealed bearings**
- **4 in 1:** standard fitted for 12 x 142 mm thru axle, conversion kit for QR 5 mm (art. 320291), 10 x 135 mm, 12 x 135 mm optionally available
- for 10 and 11 speed (Shimano Road and MTB)
- convertible to Sram XD Drive by cassette body art. 326293 and for 12 speed Sram cassettes by XD and XDR Drive cassette body art. 326272
- only **229 g**
- OLD: 142 mm
- PCD 34/47 mm, FTF 68 mm, Offset: 6.3 mm
- in Novatec box

28 hole

24 hole

conversion kit for 5 x 135 mm quick release

4 IN 1

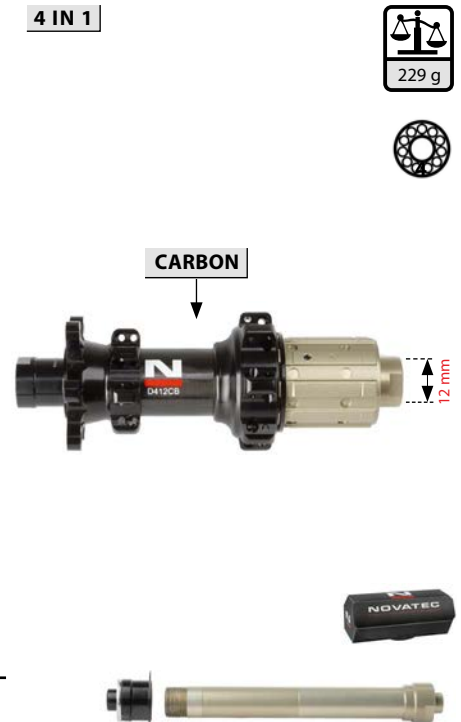

SUPERLIGHT

FRONT

SUPERLIGHT

VORDERRADSCHWIBEN- BREMSNABE ›D791SB/A‹

- 32 Loch
- **4 in 1:** ausgestattet mit **5 mm Aluminium Schnellspanner**, optional umrüstbar durch Ausgleichshülsen für 9 mm (Art. 320118) Schnellspanner, 12 mm (Art. 320119) und 15 mm (Art. 320120) Steckachse
- **2 japanische Industriekugellager**
- Aluminium-Achse
- nur **157 g** (ohne Schnellspanner)
- Einbaumaß: 100 mm
- PCD: 58/45 mm, FTF: 62 mm
- A: 26,2 mm, B: 11,8 mm
- im Novatec Einzelkarton

326420 schwarz eloxiert

326423 rot eloxiert

UVP 74,90 €

FRONT DISC BRAKE HUB ›D791SB/A‹

- 32 hole
- **4 in 1:** equipped with **5 mm aluminium quick release**, optionally convertible through spacers to 9 mm (art. 320118) QR, 12 mm (art. 320119) and 15 mm (art. 320120) thru axle
- **2 Japanese sealed bearings**
- aluminium axle
- only **157 g** (w/o quick release)
- OLD: 100 mm
- PCD: 58/45 mm, FTF: 62 mm
- A: 26.2 mm, B: 11.8 mm
- in Novatec box

black anodised

red anodised

4 IN 1



326417 • **32 Loch**

UVP 64,90 €

- **4 in 1:** vorbereitet für **15 mm Steckachse**, optional umrüstbar durch Ausgleichshülsen auf 5 mm (Art. 320117), 9 mm (Art. 320118) Schnellspanner und 12 mm (Art. 320119) Steckachse
- nur **141 g** (ohne Steckachse)

• **32 hole**

- **4 in 1:** prepared for **15 mm thru axle**, optionally convertible through spacers to 5 mm (art. 320117), 9 mm (art. 320118) QR and 12 mm (art. 320119) thru axle
- only **141 g** (w/o thru axle)



326416 • **24 Loch**

UVP 64,90 €

- **4 in 1:** vorbereitet für **12 mm Steckachse**, optional umrüstbar durch Ausgleichshülsen für 5 mm (Art. 320117) oder 9 mm (Art. 320118) Schnellspanner und 15 mm (Art. 320120) Steckachse
- nur **141 g** (ohne Steckachse)

• **24 hole**

- **4 in 1:** prepared for **12 mm thru axle**, optionally convertible through spacers to 5 mm (art. 320117) or 9 mm (art. 320118) QR and 15 mm thru axle (art. 320120)
- only **141 g** (w/o thru axle)



326448 • **28 Loch**

UVP 64,90 €

- **4 in 1:** vorbereitet für **12 mm Steckachse**, optional umrüstbar durch Ausgleichshülsen für 5 mm (Art. 320280) oder 9 mm Schnellspanner und für 15 mm Steckachse
- für **Centerlock** Bremsscheiben
- nur **141 g** (ohne Steckachse)

• **28 hole**

- **4 in 1:** prepared for **12 mm thru axle**, optionally convertible through spacers to 5 mm (art. 320280) or 9 mm QR and to 15 mm thru axle
- for **centerlock** brake discs
- only **141 g** (w/o thru axle)

CENTERLOCK



Ausgleichshülsen für Nabenmodell D791SB

320117 für 5 mm Schnellspanner

320118 für 9 mm Schnellspanner

320119 für 12 mm Schnellspanner

320120 für 15 mm Steckachse

UVP 11,90 €

spacers for hub type D791SB

for 5 mm quick release

for 9 mm quick release

for 12 mm quick release

for 15 mm thru axle

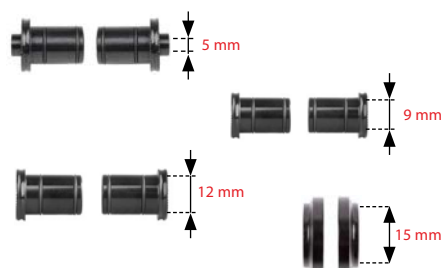

SUPERLIGHT

REAR

SUPERLIGHT

HINTERRADSCHWINGEL- BREMSNABE ›D792SB/A-AA‹

- 32 Loch
- **4 in 1:** ausgestattet mit 5 mm Aluminium-Schnellspanner, optional umrüstbar durch Umrüstsets für 10 mm (Art. 320079), 12 mm (Art. 320080) und X12 Steckachse (Art. 320081)
- **4 japanische Industriekugellager**
- Aluminium-Achse
- kompatibel mit Shimano 8-11-fach (MTB+Road)
- umrüstbar auf Sram XD Drive durch Kassettenkörper Art. 326293 und für 12-fach Sram-Kassetten durch XD und XDR Drive Kassettenkörper Art. 326272
- nur **269 g** (ohne Schnellspanner)
- Einbaumaß: 135 mm
- PCD: 58/49 mm, FTF: 56,4 mm
- A: 31,5 mm, B: 47,1 mm
- im Novatec Einzelkarton

326450 schwarz eloxiert

326453 rot eloxiert

UVP 137,00 €

REAR DISC BRAKE HUB ›D792SB/A-AA‹

- 32 hole
- **4 in 1:** equipped with aluminium quick release (5 mm), optionally convertible through spacers to 10 mm thru axle (art. 320079), 12 mm thru axle (art. 320080) and X12 thru axle (art. 320081)
- **4 Japanese sealed bearings**
- aluminium axle
- compatible with Shimano 8-11speed (MTB+Road)
- convertible to Sram XD Drive by cassette body art. 326293 and for 12 speed Sram cassettes by XD and XDR Drive cassette body art. 326272
- only **269 g** (w/o quick release)
- OLD: 135 mm
- PCD: 58/49 mm, FTF: 56.4 mm
- A: 31.5 mm, B: 47.1 mm
- in Novatec box

black anodised

red anodised

4 IN 1



- **4 in 1:** vorbereitet für **12 x 142 mm Steckachse**, optional umrüstbar durch Ausgleichshülsen auf 5 mm Schnellspanner (Art. 320112) und 10 mm Steckachse (Art. 320079) sowie 12 x 135 mm Steckachse (Art. 320080)
- Einbaumaß: 142 mm

Kassettenfreilaufkörper passend für Shimano 8-11fach (MTB + Road)

326460 32 Loch

326473 24 Loch

326449 • 28 Loch

UVP 132,00 €

- für **Centerlock** Bremsscheiben
- optional umrüstbar durch Ausgleichshülsen auf 5 mm Schnellspanner (Art. 320282)

- **4 in 1:** prepared for **12 x 142 mm thru axle**, optionally convertible through spacers to 5 mm quick release (art. 320112) and 10 mm thru axle (art. 320079) as well as 12 x 135 mm thru axle (art. 320080)
- OLD: 142 mm

cassette body suitable for Shimano 8-11speed (MTB+Road)

32 hole

24 hole

• 28 hole

- for **centerlock** brake discs
- optionally convertible through spacers to 5 mm quick release (art. 320282)



CENTERLOCK



326463 • 32 Loch

UVP 128,00 €

- Kassettenfreilaufkörper passend für **Sram**, mit XD Drive für XX1, silber (Ersatzkassettenfreilaufkörper Art. 326293)

• 32 hole

- cassette body suitable for **Sram**, with XD Drive for XX1, silver (replacement cassette body art. 326293)

Umrüstsets für Nabenmodell D792SB

spacers for hub type D792SB

320112
UVP 19,90 €

Umrüstset, CrMo, für 5 mm Schnellspanner

conversion kit, CrMo, for 5 mm QR

320079
UVP 29,90 €

Umrüstset, CrMo, für 10 mm Steckachse, mit Schnellspanner

conversion kit, CrMo, for 10 mm thru axle, with QR

320080
UVP 19,90 €

Umrüstset, CrMo, für 12 mm Steckachse, Einbaumaß: 135 mm

conversion kit, CrMo, for 12 mm thru axle, OLD: 135 mm

320081
UVP 19,90 €

Umrüstset, CrMo, für X12 Steckachse, Einbaumaß: 142 mm

conversion kit, CrMo, for X12 thru axle, OLD: 142 mm

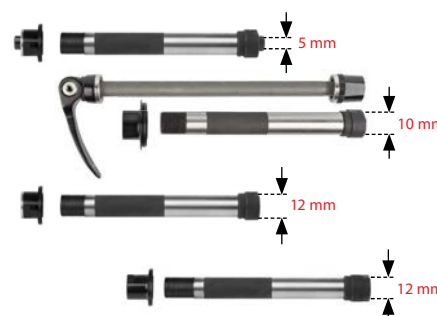

ENDURO/ROAD

ENDURO/ROAD

325123 VORDERRADSCHIBEN-BREMSNABE ›D811SB-15‹
UVP 49,90 €

- 32 Loch
- für **15 mm Steckachse**
- **2 Industriekugellager**
- nur 173 g
- Einbaumaß: 100 mm
- PCD: 58/45 mm, FTF: 62 mm
A: 26,2 mm, B: 11,8 mm
- im Novatec Einzelkarton

FRONT DISC BRAKE HUB ›D811SB-15‹

- 32 hole
- for **15 mm thru axle**
- **2 sealed bearings**
- only 173 g
- OLD: 100 mm
- PCD: 58/45 mm, FTF: 62 mm
A: 26.2 mm, B: 11.8 mm
- in Novatec box

Ø 15 MM



321443 HINTERRADSCHIBENBREMS-NABE ›D982TSB-X12-11S‹
UVP 59,90 €

- 32 Loch
- für **12 mm Steckachse**
- **2 Industriekugellager**
- für 8-11(MTB)-fach Shimano Kassette
- Einbaumaß: **142 mm**
- PCD: 58/49 mm, FTF: 63,1 mm
A: 35,4 mm, B: 49,3 mm
- Montageverpackung

REAR DISC BRAKE HUB ›D982TSB-X12-11S‹

- 32 hole
- for **12 mm thru axle**
- **2 sealed bearings**
- for 8-11(MTB) speed Shimano cassette
- OLD: **142 mm**
- PCD: 58/49 mm, FTF: 63.1 mm
A: 35.4 mm, B: 49.3 mm
- OEM

Ø 12 MM



BOOST

BOOST

326500 VORDERRADSCHIBEN-BREMSNABE ›XDS641SB-B15‹
UVP 109,00 €

- **Boost**
- Aluminium **Straight Pull**
- **28 Loch**
- für **15 mm Steckachse**
- 2 Industriekugellager
- Gewicht: 170 g
- Einbaumaß: **110 mm**
- PCD: 37 mm, FTF: 77,5 mm
Offset: 6,5 mm
- Montageverpackung

FRONT DISC BRAKE HUB ›XDS641SB-B15‹

- **Boost**
- aluminium **Straight Pull**
- **28 hole**
- for **15 mm thru axle**
- 2 sealed bearings
- weight: 170 g
- OLD: **110 mm**
- PCD: 37 mm, FTF: 77.5 mm
Offset: 6.5 mm
- OEM

OLD 110

2 IN 1



326502 HINTERRADSCHIBENBREMS-NABE ›XDS642SB-B12-ABG‹
UVP 229,00 €

- **Boost**
- Aluminium **Straight Pull**
- **28 Loch**
- für **12 mm Steckachse**
- **5 Industriekugellager**
- für 8-11 (MTB)-fach Shimano
- nur 337 g
- Kassettensfreilaufkörper mit **6 Sperrklinken, Anti-Bite-Guard** und Ratchet Ring mit 42 Zähnen für schnelle Kraftübertragung fast **ohne Verzögerung**
- Ersatzkassettensfreilaufkörper Shimano Art. 326296
- umrüstbar auf Sram XD Drive durch Kassettensfreilaufkörper Art. 326286
- Einbaumaß: **148 mm**
- Montageverpackung

REAR DISC BRAKE HUB ›XDS642SB-B12-ABG‹

- **Boost**
- aluminium **Straight Pull**
- **28 hole**
- for **12 mm thru axle**
- **5 sealed bearings**
- for 8-11(MTB) speed Shimano
- only 337 g
- cassette body with **6 pawls, anti-bite-guard** and ratchet ring with 42 teeth for fast power transmission nearly **without delay**
- replacement cassette body Shimano art. 326296
- convertible to Sram XD Drive through cassette body art. 326286
- OLD: **148 mm**
- OEM

OLD 148



BOOST

BOOST

326137 VORDERRADSCHWINGEN- BREMSNABE ›D791SB-B15‹

UVP 55,90 €

- **Boost**
- 32 Loch
- für **15 mm Steckachse**
- 2 Industriekugellager
- nur 146 g
- Einbaumaß: **110 mm**
- PCD: 58/45 mm, FTF: 72 mm
A: 26,7 mm, B: 12,3 mm
- im Novatec Einzelkarton

FRONT DISC BRAKE HUB ›D791SB-B15‹

- **Boost**
- 32 hole
- for **15 mm thru axle**
- 2 sealed bearings
- only 146 g
- **OLD: 110 mm**
- PCD: 58/45 mm, FTF: 72 mm
A: 26.7 mm, B: 12.3 mm
- in Novatec box

OLD 110

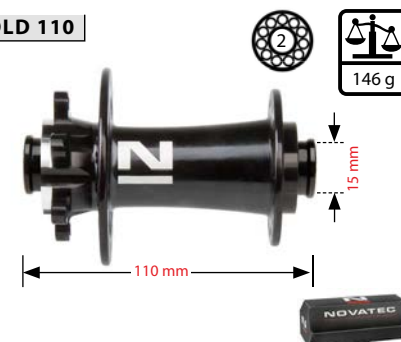

326127 HINTERRADSCHWINGEN- BREMSNABE ›D462SB‹

UVP 99,90 €

- **Boost**
- 32 Loch
- für **12 mm Steckachse**
- **5 Industriekugellager**
- Kassettenfreilaufkörper mit **5 Sperrklinken** und Ratchet Ring mit 33 Zähnen für schnelle Kraftübertragung **fast ohne Verzögerung**
- nur 325 g
- Ersatzkassettenfreilaufkörper Art. 326274
- umrüstbar auf **Microspline** Kassettenkörper Art. 326268
- umrüstbar auf Sram XD Drive durch Kassettenfreilaufkörper Art. 326031
- Einbaumaß: **148 mm**
- PCD: 62/58 mm, FTF: 62,5 mm
A: 35,2 mm, B: 50,3 mm
- im Novatec Einzelkarton

REAR DISC BRAKE HUB ›D462SB‹

- **Boost**
- 32 hole
- for **12 mm thru axle**
- **5 sealed bearings**
- cassette body with **5 pawls** and ratchet ring with 33 teeth for fast power transmission nearly **without delay**
- only 325 g
- replacement cassette body art. 326274
- conversion kit to **Microspline** cassette body art. 326268
- convertible to Sram XD Drive through cassette body art. 326031
- **OLD: 148 mm**
- PCD: 62/58 mm, FTF: 62.5 mm
A: 35.2 mm, B: 50.3 mm
- in Novatec box



326140 mit **Microspline** Kassettenkörper Art. 326268

UVP 105,00 €

- im Novatec Einzelkarton



- with **Microspline** cassette body art. 326268
- in Novatec box



- **326184** • **verstärkte Nabe** um den erhöhten Anforderungen von **E-Bikes** zu entsprechen
- für 8-11 (MTB)-fach Shimano
- 463 g
- Montageverpackung



- **reinforced hub** to conform to the increased demands of **e-bikes**
- for 8-11 (MTB) speed Shimano
- 463 g
- OEM



• 326435 HINTERRADSCHWINGEN- BREMSNABE ›D442SB-S4S-B12-MS‹

UVP 64,90 €

- **Boost**
- 32 Loch
- für **12 mm Steckachse**
- **4 Industriekugellager**
- mit **Microspline** Kassettenkörper
- Einbaumaß: **148 mm**
- PCD: 58 mm, FTF: 62,9 mm
A: 35,2 mm, B: 49,9 mm
- Montageverpackung

REAR DISC BRAKE HUB ›D442SB-S4S-B12-MS‹

- **Boost**
- 32 hole
- for **12 mm thru axle**
- **4 sealed bearings**
- with **microspline** cassette body
- **OLD: 148 mm**
- PCD: 58 mm, FTF: 62.9 mm
A: 35.2 mm, B: 49.9 mm
- OEM



BOOST

BOOST

• **326442 VORDERRADSCHIBEN-BREMSNABE ›D041SB-B15‹**

UVP 34,90 €

- **Boost**
- Aluminium
- 32 Loch
- für **15 mm Steckachse**
- nur 298 g
- Einbaumaß: **110 mm**
- PCD: 58 mm, FTF: 72 mm
- A: 26,2 mm, B: 11,8 mm
- neutral, ohne Logo
- Montageverpackung

FRONT DISC BRAKE HUB ›D041SB-B15‹

- **boost**
- aluminium
- 32 hole
- for **15 mm thru axle**
- nur 298 g
- OLD: **110 mm**
- PCD: 58 mm, FTF: 72 mm
- A: 26,2 mm, B: 11.8 mm
- neutral, without logo
- OEM

OLD 110



• **326443 HINTERRADSCHIBEN-BREMSNABE ›D952TSE-B12‹**

UVP 49,90 €

- **Boost**
- Aluminium
- 32 Loch
- für **12 mm Steckachse**
- für 8-11 (MTB)-fach Shimano
- nur 394 g
- Einbaumaß: **148 mm**
- PCD: 58/49 mm, FTF: 64 mm
- A: 35 mm, B: 49 mm
- neutral, ohne Logo
- Montageverpackung

REAR DISC BRAKE HUB ›D952TSE-B12‹

- **boost**
- aluminium
- 32 hole
- for **12 mm thru axle**
- for 8-11(MTB) speed Shimano
- only 394 g
- OLD: **148 mm**
- PCD: 58/49 mm, FTF: 64 mm
- A: 35 mm, B: 49 mm
- neutral, without logo
- OEM

OLD 148



DOWNHILL

DOWNHILL

326330 VORDERRADSCHIBEN-BREMSNABE ›DH61SB-HL‹

UVP 54,90 €

- **2 Industriekugellager**
- für **20 mm Steckachse**
- 179 g
- 32 Loch
- Einbaumaß: **110 mm**
- PCD: 58/45 mm, FTF: 60,4 mm
- A: 30,8 mm, B: 19 mm
- im Novatec Einzelkarton

FRONT DISC BRAKE HUB ›DH61SB-HL‹

- **2 sealed bearings**
- for **20 mm thru axle**
- 179 g
- 32 hole
- OLD: **110 mm**
- PCD: 58/45 mm, FTF: 60.4 mm
- A: 30.8 mm, B: 19 mm
- in Novatec box



326151 HINTERRADSCHIBEN-BREMSNABE ›DH82SB/A-SS‹

UVP 127,00 €

- **4 japanische Industriekugellager**
- für **12 mm Festachse**
- 390 g
- 32 Loch
- für 8/9/10/11(MTB)-fach Shimano
- Einbaumaß: **150 mm**
- PCD: 58/49 mm, FTF: 74,45 mm
- A: 31 mm, B: 45 mm
- im Novatec Einzelkarton

REAR DISC BRAKE HUB ›DH82SB/A-SS‹

- **4 Japanese sealed bearings**
- for **12 mm solid axle**
- 390 g
- 32 hole
- for 8/9/10/11(MTB) speed Shimano
- OLD: **150 mm**
- PCD: 58/49 mm, FTF: 74.45 mm
- A: 31 mm, B: 45 mm
- in Novatec box



FAT TIRE

FAT TIRE

326148 VORDERRADSCHNABEN- BREMSNABE ›D101SB‹

UVP 74,90 €

- für Fat Tire Bikes
- 36 Loch
- **3 in 1**: ausgestattet mit 5 mm Aluminium-Schnellspanner, optional umrüstbar für 9 mm und 15 mm
- **2 Industriekugellager**
- schwarz
- nur 208 g (ohne Schnellspanner)
- **Einbaumaß: 135 mm**
- PCD: 58 mm, FTF: 72 mm
A: 28 mm, B: 28 mm
- Montageverpackung

FRONT DISC BRAKE HUB ›D101SB‹

- for Fat Tire Bikes
- 36 hole
- **3 in 1**: equipped with aluminium quick release 5 mm, optionally convertible for 9 mm and 15 mm
- **2 sealed bearings**
- black
- only 208 g (w/o quick release)
- **OLD: 135 mm**
- PCD: 58 mm, FTF: 72 mm
A: 28 mm, B: 28 mm
- OEM

3 IN 1



326149 HINTERRADSCHNABEN- BREMSNABE ›D102SB/SS‹

UVP 111,00 €

- für Fat Tire Bikes
- 36 Loch
- **4 in 1**: ausgestattet mit 10 mm Aluminium-Schnellspanner, optional umrüstbar für 5 mm, 12 mm und X12
- **5 Industriekugellager**
- schwarz
- für 8-11(MTB)-fach Shimano
- nur 418 g (ohne Schnellspanner)
- **Einbaumaß: 170 mm**
- PCD: 58 mm, FTF: 78 mm
A: 46 mm, B: 46 mm
- Montageverpackung

REAR DISC BRAKE HUB ›D102SB/SS‹

- for Fat Tire Bikes
- 36 hole
- **4 in 1**: equipped with aluminium quick release 10 mm, optionally convertible for 5 mm, 12 mm and X12
- **5 sealed bearings**
- black
- for 8-11(MTB) speed Shimano
- only 418 g (w/o quick release)
- **OLD: 170 mm**
- PCD: 58 mm, FTF: 78 mm
A: 46 mm, B: 46 mm
- OEM

4 IN 1



326132 VORDERRADSCHNABEN- BREMSNABE ›D201SB‹

UVP 85,90 €

- für Fat Tire Bikes
- 32 Loch
- **3 in 1**: ausgestattet für 15 mm Steckachse, optional umrüstbar für 5 mm und 9 mm
- **2 Industriekugellager**
- nur 207 g
- **Einbaumaß: 150 mm**
- PCD: 58 mm, FTF: 90,6 mm
A: 26,2 mm, B: 26,2 mm
- Montageverpackung

FRONT DISC BRAKE HUB ›D201SB‹

- for Fat Tire Bikes
- 32 hole
- **3 in 1**: equipped for 15 mm thru axle, optionally convertible for 5 mm and 9 mm
- **2 sealed bearings**
- only 207 g
- **OLD: 150 mm**
- PCD: 58 mm, FTF: 90.6 mm
A: 26.2 mm, B: 26.2 mm
- OEM

3 IN 1



326134 HINTERRADSCHNABEN- BREMSNABE ›D202SB/A4A‹

UVP 143,00 €

- für Fat Tire Bikes
- 32 Loch
- **4 in 1**: ausgestattet für 12 x 197 mm Steckachse (für X-12 Schnellspanner), optional umrüstbar für 5 mm (Art. 320292), 10 mm und 12 x 190 mm
- **5 Industriekugellager**
- für 8-11(MTB)-fach Shimano
- **Einbaumaß: 197 mm**
- PCD: 58 mm, FTF: 98 mm
A: 49,2 mm, B: 52,5 mm
- Montageverpackung

REAR DISC BRAKE HUB ›D202SB/A4A‹

- for Fat Tire Bikes
- 32 hole
- **4 in 1**: equipped for 12 x 197 mm thru axle (for QR X-12), optionally convertible for 5 mm (art. 320292), 10 mm and 12 x 190 mm
- **5 sealed bearings**
- for 8-11(MTB) speed Shimano
- **OLD: 197 mm**
- PCD: 58 mm, FTF: 98 mm
A: 49.2 mm, B: 52.5 mm
- OEM

4 IN 1



320292 Umrüstset für 5 x 190 mm Schnellspanner

UVP 32,90 €

conversion kit for QR 5 x 190 mm



SEALED

SEALED

**VORDERRADSCHIEBEN-
BREMSNABE ›D041SB‹**

- mit **2 Industriekugellagern**
- 216 g (ohne Schnellspanner)
- Einbaumaß: 100 mm
- PCD: 58 mm, FTF: 62 mm
A: 26,2 mm, B: 11,8 mm
- Montageverpackung

326220 36 Loch

326222 32 Loch

UVP 39,90 €

**FRONT DISC BRAKE HUB
›D041SB‹**

- with **2 sealed bearings**
- 216 g (w/o quick release)
- OLD: 100 mm
- PCD: 58 mm, FTF: 62 mm
A: 26.2 mm, B: 11.8 mm
- OEM

36 hole

32 hole



**HINTERRADSCHIEBEN-
BREMSNABE ›D042SB‹**

- mit **4 Industriekugellagern**
- 492 g (ohne Schnellspanner)
- für 8-11-fach MTB und 8-10-fach Road Shimano Kassette
- Einbaumaß: 135 mm
- PCD: 58 mm, FTF: 58,4 mm
A: 31,5 mm, B: 45,1 mm
- Montageverpackung

326221 36 Loch

326223 32 Loch

UVP 64,90 €



**REAR DISC BRAKE HUB
›D042SB‹**

- with **4 sealed bearings**
- 492 g (w/o quick release)
- for 8-11 speed MTB and 8-10 speed road Shimano cassette
- OLD: 135 mm
- PCD: 58 mm, FTF: 58.4 mm
A: 31.5 mm, B: 45.1 mm
- OEM

36 hole

32 hole



**VORDERRADSCHIEBEN-
BREMSNABE**

- 32 Loch
- mit **2 Industriekugellagern**
- **CrMo-Achse**
- mit Schnellspanner
- Einbaumaß: **100 mm**
- PCD: 58 mm, FTF: 58 mm
A: 26,5 mm, B: 15,5 mm
- Montageverpackung

324926 36 Loch

• **324920** 32 Loch

UVP 19,90 €

FRONT DISC BRAKE HUB

- 32 holes
- with **2 sealed bearings**
- **CrMo axle**
- with quick release
- OLD: **100 mm**
- PCD: 58 mm, FTF: 58 mm
A: 26.5 mm, B: 15.5 mm
- OEM

36 hole

32 hole



**HINTERRADSCHIEBEN-
BREMSNABE**

- 32 Loch
- mit **2 Industriekugellagern**
- **CrMo-Achse**
- mit Schnellspanner
- für 8-11-fach MTB und 8-10-fach Road Shimano Kassette
- Einbaumaß: **135 mm**
- PCD: 58 mm, FTF: 58 mm
A: 31 mm, B: 46 mm
- Montageverpackung

324927 36 Loch

• **324921** 32 Loch

UVP 33,90 €

REAR DISC BRAKE HUB

- 32 holes
- with **2 sealed bearings**
- **CrMo axle**
- with quick release
- for 8-11 speed MTB and 8-10 speed road Shimano cassette
- OLD: **135 mm**
- PCD: 58 mm, FTF: 58 mm
A: 31 mm, B: 46 mm
- OEM

36 hole

32 hole



GREAT VALUE

326440 VORDERRAD-SCHEIBENBREMSNABE

UVP 14,90 €

- 36 Loch
- mit Aluminium-Schnellspanner
- Einbaumaß: 100 mm
- PCD: 58 mm, FTF: 62 mm

FRONT DISC BRAKE HUB

- 36 hole
- with aluminium quick release
- OLD: 100 mm
- PCD: 58 mm, FTF: 62 mm



GREAT VALUE

HINTERRAD-SCHEIBENBREMSNABE

- 36 Loch
- Einbaumaß: 135 mm

REAR DISC BRAKE HUB

- 36 hole
- OLD: 135 mm



- für Freilaufzahnkranz,
- PCD: 58 mm, FTF: 58 mm

UVP 14,90 €

- for freewheel,
- PCD: 58 mm, FTF: 58 mm

- für 8-11-fach MTB und 8-10-fach Road Shimano Kassette,
- PCD: 58 mm, FTF: 52 mm
- A: 31,5 mm, B: 46,4 mm

UVP 27,90 €

- for 8-11 speed MTB and 8-10 speed road Shimano cassette,
- PCD: 58 mm, FTF: 52 mm
- A: 31.5 mm, B: 46.4 mm





ULTRALIGHT

CARBON

ULTRALIGHT

326374 VORDERRADNABE ›AS61CB/A‹

UVP 97,90 €

- **UD-Carbon Straight Pull-Nabe**
- **2 japanische Industriekugellager**
- 20 Loch
- nur **69 g** (ohne Schnellspanner)
- Einbaumaß: 100 mm
- im Novatec Einzelkarton

FRONT HUB ›AS61CB/A‹

- **UD carbon straight pull hub**
- **2 Japanese sealed bearings**
- 20 hole
- only **69 g** (w/o quick release)
- OLD: 100 mm
- in Novatec box



CARBON



326375 HINTERRADNABE ›FS62CB/A-AA-115‹

UVP 149,00 €

- **UD-Carbon Straight Pull-Nabe**
- für Shimano 8-11-fach (MTB + Road)
- **1 japanisches und 3 Industriekugellager**
- 24 Loch
- nur **215 g** (ohne Schnellspanner)
- Einbaumaß: 130 mm
- umrüstbar für Campagnolo-Zahnkranz mit Kassettenfreilaufkörper Art. 325706
- im Novatec Einzelkarton

REAR HUB ›FS62CB/A-AA-115‹

- **UD carbon straight pull hub**
- for Shimano 8-11 speed (MTB + Road)
- **1 Japanese and 3 sealed bearings**
- 24 hole
- only **215 g** (w/o quick release)
- OLD: 130 mm
- convertible for Campagnolo sprocket with cassette body art. 325706
- in Novatec box

LIGHTEST ROAD REAR

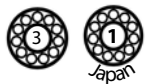

CARBON



325175 VORDERRADNABE ›A291SB/A-SL‹

UVP 66,90 €

- 20 Loch
- **2 japanische Industriekugellager**
- nur **59 g** (ohne Schnellspanner)
- mit **abnehmbarem** Schnellspannhebel
- Speichenlöcher auch passend für Aero-Speichen (bis 2,5 mm)
- Einbaumaß: 100 mm
- PCD: 30 mm, FTF: 68,7 mm
- A: 16 mm, B: 16 mm
- im Novatec Einzelkarton

FRONT HUB ›A291SB/A-SL‹

- 20 hole
- **2 Japanese sealed bearings**
- only **59 g** (w/o quick release)
- with **removable** quick release lever
- holes also suitable for Aero spokes (up to 2.5 mm)
- OLD: 100 mm
- PCD: 30 mm, FTF: 68.7 mm
- A: 16 mm, B: 16 mm
- in Novatec box

LIGHTEST ROAD FRONT



SUPERLIGHT

SUPERLIGHT

VORDERRADNABE ›A291SB‹

- mit **2 Industriekugellagern**
- mit **abnehmbarem** Schnellspannhebel
- Speichenlöcher auch passend für Aero-Speichen (bis 2,5 mm)
- Einbaumaß: 100 mm
- PCD: 30 mm, FTF: 68,7 mm
A: 15,6 mm, B: 15,6 mm
- im Novatec Einzelkarton

325268 32 Loch, **76 g** (ohne Schnellspanner)
325353 28 Loch, Montageverpackung
325210 20 Loch

UVP 42,90 €

FRONT HUB ›A291SB‹

- with **2 sealed bearings**
- with **removable** quick release lever
- holes also suitable for Aero spokes (up to 2.5 mm)
- OLD: 100 mm
- PCD: 30 mm, FTF: 68.7 mm
A: 15.6 mm, B: 15.6 mm
- in Novatec box

32 hole, **76 g** (w/o quick release)
 28 hole, OEM
 20 hole



HINTERRADNABE ›F482SB/A4A-11S‹

- mit **4 Industriekugellagern**
- Aluminium-Kassettenfreilaufkörper
- für **8-11-fach** Shimano Kassette (MTB + Road)
- umrüstbar für Campagnolo-Zahnkranz mit Kassettenfreilaufkörper Art. 325706
- **235 g** (ohne Schnellspanner)
- Speichenlöcher auch passend für Aero-Speichen (bis 2,5 mm)
- Einbaumaß: 130 mm
- PCD: 41/49 mm, FTF: 57 mm
A: 27,2 mm, B: 47,4 mm
- im Novatec Einzelkarton

326080 32 Loch
326081 24 Loch

UVP 89,90 €

REAR HUB ›F482SB/A4A-11S‹

- with **4 sealed bearings**
- aluminium cassette body
- for **8-11** speed Shimano cassette (MTB + road)
- convertible for Campagnolo sprocket with cassette body art. 325706
- **235 g** (w/o quick release)
- holes also suitable for Aero spokes (up to 2.5 mm)
- OLD: 130 mm
- PCD: 41/49 mm, FTF: 57 mm
A: 27.2 mm, B: 47.4 mm
- in Novatec box

32 hole
 24 hole



LIGHT + SEALED + NICE PRICE

LIGHT+ SEALED + NICE PRICE

VORDERRADNABE ›A141SB‹

- mit **2 austauschbaren Industriekugellagern**
- **118 g** (ohne Schnellspanner)
- Einbaumaß: 100 mm
- PCD: 38 mm, FTF: 72 mm
A: 14 mm, B: 14 mm
- Montageverpackung

325156 36 Loch
325157 32 Loch

UVP 21,90 €

FRONT HUB ›A141SB‹

- with **2 replaceable sealed bearings**
- **118 g** (w/o quick release)
- OLD: 100 mm
- PCD: 38 mm, FTF: 72 mm
A: 14 mm, B: 14 mm
- OEM

36 hole
 32 hole



HINTERRADNABE ›F162SB/AA-11S‹

- mit **4 Industriekugellagern**
- **276 g** (ohne Schnellspanner)
- für 8-11-fach Road + MTB Shimano Kassette mit **3 Sperrklinken** (Ersatzkassettenfreilaufkörper Art. 326292)
- umrüstbar auf Campagnolo Art. 325283
- Einbaumaß: 135 mm
- PCD: 49 mm, FTF: 57,3 mm
A: 31,25, B: 46,45
- Montageverpackung

325158 36 Loch
325159 32 Loch

UVP 59,90 €

REAR HUB ›F162SB/AA-11S‹

- with **4 sealed bearings**
- **276 g** (w/o quick release)
- for 8-11 speed road + MTB Shimano cassette with **3 pawls** (replacement cassette body art. 326292)
- convertible to Campagnolo art. 325283
- OLD: 135 mm
- PCD: 49 mm, FTF: 57.3 mm
A: 31.25, B: 46.45
- OEM

36 hole
 32 hole



VORDERRADNABE ›A565SBT‹

- für Vorderrad Hochflansch
- mit 2 **Industriekugellagern**
- **CrMo**-Achse M9 x 140 mm
- Einbaumaß: 100 mm
- PCD: 62 mm, FTF: 70 mm
- A: 15 mm, B: 15 mm
- Montageverpackung

326700 • 36 Loch

UVP 38,90 €

- silber

326701 • 32 Loch

UVP 39,90 €

- schwarz eloxiert

• **325932** Modell ›Eco‹

UVP 17,90 €

- 32 Loch
- **Aluminium**-Dichtungsscheiben
- silber
- PCD: 63 mm, FTF: 70 mm

FRONT HUB ›A565SBT‹

- front high flange
- with 2 **sealed bearings**
- **CrMo** axle M9 x 140 mm
- OLD: 100 mm
- PCD: 62 mm, FTF: 70 mm
- A: 15 mm, B: 15 mm
- OEM

• **36 hole**

- silver

• **32 hole**

- black anodised

model ›Eco‹

- 32 hole
- sealed **aluminium** washers
- silver
- PCD: 63 mm, FTF: 70 mm



HINTERRADNABE ›A566SBT‹

- für Hinterrad Hochflansch
- 32 Loch
- mit 2 **Industriekugellagern**
- **CrMo**-Achse M10 x 165 mm
- Einbaumaß: 120 mm
- PCD: 62 mm, FTF: 59 mm
- A: 30,5 mm, B: 30,5 mm
- Montageverpackung

Gewinde 1,37" und 1,29" **beidseitig**

326702 • 36 Loch

- silber

326703 • 32 Loch

UVP 51,90 €

- schwarz eloxiert

REAR HUB ›A566SBT‹

- rear high flange
- 32 hole
- with 2 **sealed bearings**
- **CrMo** axle M10 x 165 mm
- OLD: 120 mm
- PCD: 62 mm, FTF: 59 mm
- A: 30.5 mm, B: 30.5 mm
- OEM

thread 1.37" and 1.29" on **both sides**

• 36 hole

- silver

• 32 hole

- black anodised



326704 • free/ fixed

UVP 44,90 €

- Gewinde 1,37" und 1,37/1,29"
- schwarz eloxiert

• **free/ fixed**

- thread 1.37" and 1.37/1.29"
- black anodised

• **325933** Modell ›Eco‹

UVP 24,90 €

- **Aluminium**-Dichtungsscheiben
- silber
- PCD: 62 mm, FTF: 60 mm

model ›Eco‹

- sealed **aluminium** washers
- silver
- PCD: 62 mm, FTF: 60 mm

BAHN/SINGLE SPEED- NABENZUBEHÖR

329907 Mutter für **VR**-Bahn-Naben
UVP 1,90 € (Art. 326700, ...)

329908 Mutter für **Hinterrad**-Bahn-Naben
UVP 1,90 € (Art. 326702, ...)

329909 Zahnkranzverschlussring für
UVP 3,90 € Hinterrad-Naben (Art. 326702, ...)

TRACK/SINGLE SPEED HUB ACCESSORIES

nut for **front** track hubs
(art. 326700, ...)

nut for **rear** track hubs
(art. 326702, ...)

lock ring for rear hubs
(art. 326702, ...)

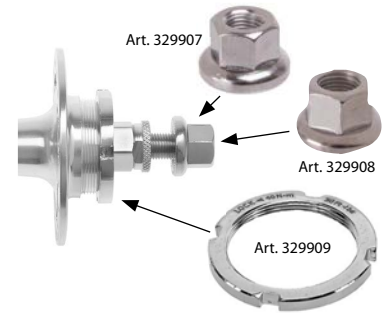

ZAHNKRANZ 1/2 X 1/8"

325797 13 Zähne

325591 14 Zähne

325592 15 Zähne

325593 16 Zähne

325604 17 Zähne

325594 18 Zähne

UVP 4,90 €

SPROCKET 1/2 X 1/8"

13 teeth

14 teeth

15 teeth

16 teeth

17 teeth

18 teeth



SCHNELLSPANNER / QUICK RELEASES

SCHNELLSPANNER

- Aluminium
- schwarz eloxiert
- Montageverpackung

321122 • für Vorderradnabe
• Einbaumaß: 100 mm
• nur **39 g**

321123 • für Hinterradnabe
• Einbaumaß: 135 mm
• nur **45 g**

QUICK RELEASE

- aluminium
- black anodised
- OEM

• for front hub
• OLD: 100 mm
• only **39 g**

• for rear hub
• OLD 135 mm
• only **45 g**



321060 Set aus Schnellspannern für Vorderrad-
UVP 12,90 € nabe (Art. 321122) und für Hinterradnabe
(Art. 321123)
• nur **84 g/Set**
• auf Novatec Eurolochkarte

Set of quick releases for front hub
(art. 321122) and for rear hub
(art. 321123)
• only **84 g/set**
• on Novatec eurohole card



STECKACHSE MIT HEBEL

- Aluminium
- Ausrichtung des Hebels auch in geschlossenem Zustand änderbar
- im Polybeutel mit Novatec Euroloch-header

THRU AXLE WITH LEVER

- aluminium
- adjustable position of lever even when closed
- in PE bag with Novatec eurohole header



›QR269F‹

- 321086** • Einbaumaß 12 x 100 mm
- M12 x Länge 118,5 mm
 - Gewindesteigung 1,5 mm
 - Gewindelänge 10,5 mm
 - passend für z. B. Art. 391570
- UVP 34,90 €

›QR269F‹

- OLD 12 x 100 mm
- M12 x length 118.5 mm
 - thread pitch: 1.5 mm
 - thread length: 10.5 mm
 - suitable for e. g. art. 391570



- 321097** • Einbaumaß 15 x 100 mm
- M15 x Länge 148 mm
 - Gewindesteigung 1,5 mm
 - Gewindelänge 10 mm
 - passend für z. B. Art. 395040 und diverse Rockshox Gabeln
- UVP 34,90 €

- OLD 15 x 100 mm
- M15 x length 148 mm
 - thread pitch: 1.5 mm
 - thread length: 10 mm
 - suitable for e. g. art. 395040 and other Rockshox forks



- 321096** ›QR269R‹
- Einbaumaß 142 mm (X12)
 - M12 x Länge 166 mm
 - Gewindesteigung 1,5 mm
 - Gewindelänge 10 mm
- UVP 34,90 €

- ›QR269R‹
- OLD 142 mm (X12)
 - M12 x length 166 mm
 - thread pitch: 1.5 mm
 - thread length: 10 mm



- 321070** ›QR264 SYNTACE‹
- Einbaumaß 142 mm (X12)
 - M12 x Länge 163 mm
 - Gewindesteigung 1 mm
 - Gewindelänge 20 mm
- UVP 34,90 €

- ›QR264 SYNTACE‹
- OLD 142 mm (X12)
 - M12 x length 163 mm
 - thread pitch: 1 mm
 - thread length: 20 mm



- 321071** ›QR264 SHIMANO‹
- Einbaumaß 142 mm (X12)
 - M12 x Länge 172 mm
 - Gewindesteigung 1,5 mm
 - Gewindelänge 18 mm
 - für Shimano-X12 (kein original Shimano Ersatzteil)
 - z. B. für 661953 ff, ...
- UVP 34,90 €

- ›QR264 SHIMANO‹
- OLD 142 mm (X12)
 - M12 x length 172 mm
 - thread pitch: 1.5 mm
 - thread length: 18 mm
 - for Shimano-X12 (no original Shimano spare part)
 - e. g. for 661953 et seq., ...



Steckachse mit anderem Durchmesser, Länge, ... auf Anfrage erhältlich

Thru axle with other diameter, length, ... available on request



KASSETTENFREILAUFKÖRPER

im Novatec Einzelkarton

CASSETTE BODY

in Novatec Box

INFO

Welcher Kassettenfreilaufkörper passt zu meiner Nabe? - Siehe Seite 28.

Which cassette body fits to my hub? - Just have a look on page 28.



ANTI-BITE-GUARD



SHIMANO TYP

326283 Typ ›B2‹
 • **Aluminium**
 UVP 59,90 € • für 8-11-fach **Shimano** Kassette (Road + MTB)
 • 4 Sperrklinken
 • mit **Anti-Bite-Guard**

326294 Typ ›B2‹
 • **Aluminium**
 UVP 37,90 € • für 8-11-fach **Shimano** Kassette (Road + MTB)
 • 4 Sperrklinken

326274 Typ ›F‹
 • **Aluminium**
 UVP 49,90 € • für 8-10-(Road) + 11 (MTB)-fach **Shimano** Kassette
 • **5 Sperrklinken**

326292 Typ ›A2‹
 • **Aluminium**
 UVP 36,90 € • für 8-11-fach **Shimano** Kassette (Road + MTB)

325725 Typ ›B1‹
 • **Aluminium**
 UVP 36,90 € • für 8-10-(Road) + 11 (MTB)-fach **Shimano** Kassette
 • 4 Sperrklinken

325285 Typ ›B LS‹
 • für 8-10-(Road) + 11 (MTB)-fach **Shimano** Kassette
 UVP 36,90 €

›B2‹ type
 • **aluminium**
 • for 8-11 speed **Shimano** cassette (road + MTB)
 • 4 pawls
 • with **Anti-Bite-Guard**

›B2‹ type
 • **aluminium**
 • for 8-11 speed **Shimano** cassette (road + MTB)
 • 4 pawls

›F‹ type
 • **aluminium**
 • for 8-10 (road) + 11 (MTB) speed **Shimano** cassette
 • **5 pawls**

›A2‹ type
 • **aluminium**
 • for 8-11 speed **Shimano** cassette (road + MTB)

›B1‹ type
 • **aluminium**
 • for 8-10 (road) + 11 (MTB) speed **Shimano** cassette
 • 4 pawls

›B LS‹ type
 • for 8-10 (road) + 11 (MTB) speed **Shimano** cassette

CAMPAGNOLO TYP

325283 Typ ›A‹
 • **Aluminium**
 UVP 42,90 € • für 9-12-fach **Campagnolo** Kassette

325706 Typ ›B1‹
 • **Aluminium**
 UVP 42,90 € • für 9-12-fach **Campagnolo** Kassette

326266 Typ ›B1‹
 • **Aluminium**
 UVP 59,90 € • für 13-fach **Campagnolo** Kassette

›A‹ type
 • **aluminium**
 • for 9-12-speed **Campagnolo** cassette

›B1‹ type
 • **aluminium**
 • for 9-12-speed **Campagnolo** cassette

›B1‹ type
 • **aluminium**
 • for 13-speed **Campagnolo** cassette

SRAM TYP

SRAM TYPE

XD Drive: für **Sram** XG-Kassetten

XD Drive: for **Sram** XG cassettes

- 326286** Typ ›XX1‹
 UVP 82,90 €
 • **Aluminium**
 • **6 Sperrklinken**
 • im Polybeutel

- ›XX1‹ type
 • **aluminium**
 • **6 pawls**
 • in PE bag



- 326031** Typ ›F‹
 UVP 49,90 €
 • **3 Sperrklinken**
 • im Novatec Einzelkarton

- ›F‹ type
 • **3 pawls**
 • in Novatec box



- 326293** Typ ›B‹
 UVP 57,90 €
 • **4 Sperrklinken**
 • im Novatec Einzelkarton

- ›B‹ type
 • **4 pawls**
 • in Novatec box



XDR Drive: für 11-/12-fach **Sram** XG-Kassette

XDR Drive: for 11/12 speed **Sram** XG-cassette

- 326272** Typ ›B‹
 UVP 69,90 €
 • **Aluminium**
 • schwarz
 • im Novatec Einzelkarton

- ›B‹ type
 • **aluminium**
 • black
 • in Novatec box



INFO

Welches Umrüstset benötige ich? Which conversion kit do I need?

| Vorderradnabe front hub | 5 mm | 9 mm | 12 mm | 15 mm | 20 mm |
|----------------------------|--------|--------|--------|--------|--------|
| D411 | 320290 | | 320107 | | |
| D791 | 320117 | 320118 | 320119 | 320120 | |
| D791-CL | 320281 | | | 320098 | |
| XD611-CL | 320110 | 320092 | 320111 | 320093 | |
| D541 | 320094 | | | 320293 | |
| D101 | | | | | |
| D201 | 320117 | 320118 | 320119 | 320297 | |
| D881 | 320094 | | | 320293 | 325897 |
| XD641SB-B15 | | | | | 320123 |
| 30 Disc | 320117 | 320118 | 320119 | 320120 | |
| Diablo | 320094 | | | 320293 | 325897 |
| Diablo XL | | | | | 320123 |
| Flowtrail | 320094 | | | 320293 | 325897 |
| Alpine | 320094 | | | 320293 | 325897 |
| Dragon | 320094 | | | 320293 | 325897 |
| Demon | 320094 | | | 320293 | 325897 |
| CXD 4.0 | 320117 | 320118 | 320119 | 320120 | |
| Jetfly Disc 4.0 | 320117 | 320118 | 320119 | 320120 | |
| R3 Disc 3.0/4.0 | 320290 | | 320107 | | |

| Hinterradnabe rear hub | 5x135 | 10x135 | 12x135 | 12x142 |
|---------------------------|--------|--------|--------|--------|
| D412 | 320291 | | | |
| D792 | 320112 | 320079 | 320080 | 320081 |
| D792-CL | 326282 | | | |
| XD612 | 320112 | 320079 | 320080 | 320081 |
| D542 | | | | 320069 |
| D102 | | | | |
| D202 | 320292 | | | 325472 |
| Diablo | 320095 | | | 320096 |
| Flowtrail | 320095 | | | 320096 |
| Alpine | 320095 | | | 320096 |
| Dragon | 320095 | | | 320096 |
| Demon | | | | |
| CXD 4.0 | 320112 | 320079 | 320080 | 320081 |
| Jetfly Disc 4.0 | 320112 | 320079 | 320080 | 320081 |
| R3 Disc 3.0 | 320112 | 320079 | 320080 | 320081 |
| R3 Disc 4.0 | 320291 | | | |

INFO Welcher Kassettenfreilaufkörper passt zu meiner Nabe/lauftrad?
Which cassette body fits to my hub resp. wheel set?

| Art. Nabe/Lauftrad art. hub/wheelset | Modell Nabe/Lauftrad model hub / wheelset | Body- Type | Shimano | Microspline | Campagnolo | XD-Drive (Sram) | XDR-Drive |
|---|--|----------------|-------------------------|-------------|------------|--------------------|-----------|
| 321405 | D142SB-X12 | S5 | 326288 | - | - | - | - |
| 325158 | F162SB-11S | A2 | 326292 | - | 325283 | - | - |
| 325159 | F162SB-11S | A2 | 326292 | - | 325283 | - | - |
| 325198 | D722SB-11S | B2 | 326294, 326283 with ABG | - | 325706 | 326293 | 326272 |
| 326080 | F482SB-11S | B2 | 326294 | - | 325706 | - | 326272 |
| 326081 | F482SB-11S | B2 | 326294 | - | 325706 | - | 326272 |
| 326082 | F482SB-11S | B2 | 326294 | - | 325706 | - | 326272 |
| 326088 | F172SB-11S | A2 | 326292 | - | 325283 | - | - |
| 326089 | F172SB-11S | A2 | 326292 | - | 325283 | - | - |
| 326101 | D042SB | A | 325281 | - | 325283 | - | - |
| 326118 | D712SB-B12 | B1 | 325725 | - | - | 326293 | 326272 |
| 326131 | D102SB | B | 325285 | - | - | 326293 | 326272 |
| 326134 | D202SB | B1 | 325725 | - | - | 326293 | 326272 |
| 326151 | DH82SB | B | 325285 | - | - | 326393 | 326272 |
| 326181 | D542SB | XS | - | - | - | - | - |
| 326321 | D042SB | A | 325281 | - | - | - | - |
| 326323 | D042SB | A | 325281 | - | - | - | - |
| 326354 | D772SB-11S | B2 | 326294, 326283 with ABG | - | - | 326293 | 326272 |
| 326355 | D772SB-11S | B2 | 326294, 326283 with ABG | - | - | 326293 | 326272 |
| 326356 | D772SB-11S | B2 | 326294, 326283 with ABG | - | - | 326293 | 326272 |
| 326361 | D772SB-11S | B2 | 326294, 326283 with ABG | - | - | 326293 | 326272 |
| 326362 | D772SB-11S | B2 | 326294, 326283 with ABG | - | - | 326293 | 326272 |
| 326363 | D772SB-11S | B2 | 326294, 326283 with ABG | - | - | 326293 | 326272 |
| 326333 | D772SB-11S | B2 | 326294, 326283 with ABG | - | - | 326293 | 326272 |
| 326335 | D772SB-11S | B2 | 326294, 326283 with ABG | - | - | 326293 | 326272 |
| 326450 | D792SB-11S | B2 | 326294, 326283 with ABG | - | - | 326293 | 326272 |
| 326452 | D792SB-11S | B2 | 326294, 326283 with ABG | - | - | 326293 | 326272 |
| 326453 | D792SB-11S | B2 | 326294, 326283 with ABG | - | - | 326293 | 326272 |
| 326454 | D792SB-11S | B2 | 326294, 326283 with ABG | - | - | 326293 | 326272 |
| 326455 | D792SB-11S | B2 | 326294, 326283 with ABG | - | - | 326293 | 326272 |
| 326456 | D792SB-11S | B2 | 326294, 326283 with ABG | - | - | 326293 | 326272 |
| 326460 | D792SB-11S | B2 | 326294, 326283 with ABG | - | - | 326293 | 326272 |
| 326461 | D792SB-11S | B2 | 326294, 326283 with ABG | - | - | 326293 | 326272 |
| 326127 | D462SB-B12 | F | 326274 | 326268 | - | 326031 | - |
| 326184 | D462SB-SL-B12/A-S3S-11S | F | 326274 | 326268 | - | 326031 | - |
| 321440 | D162SB-SL-X12 | F (Loose ball) | | | | | |
| 326375 | FS62CB-11S | B2 | 326294 | - | - | - | 326272 |
| 326379 | D412CB-11S | B2 | 326294 | - | - | 326293 | 326272 |
| 326501 | DS462SB-A5A-B12 | F | 326274 | - | - | 326031 | - |
| 326502 | XDS642SB-B12-ABG | X4 | 326296 | - | - | 326286 | - |
| 326572 | D932SB-B12 | E | | - | - | 326282 | - |
| 384126 | R5 Clincher | D2 | 326297 | - | 326298 | - | - |
| 384213 | R3 Clincher Disc 4.0 | B2 | 326294, 326283 with ABG | - | - | 326293 | 326272 |
| 384128 | R3 Clincher Disc 3.0 | D2 | 326297 | - | 326298 | - | - |
| 384144 | Demon U2.1 | X4 | 326296 | - | - | 326286 | - |
| 384159 | Thirty U1.1 | | | - | - | - | - |
| 384179 | Jetfly Disc 4.0 | B2 | 326294, 326283 with ABG | - | - | 326293 | 326272 |
| 384181 | CXD 4.0 | B2 | 326294, 326283 with ABG | - | - | 326293 | 326272 |
| 384182 | Jetfly SL U1.1 | D2 | 326297 | - | 326298 | - | - |
| 384184 | Thirty Disc 1.1 | | | - | - | - | - |
| 384236 | Flowtrail 2.1 - Boost | X4 | 326296 | - | - | 326286 | - |
| 384237 | Flowtrail 2.1 - Boost | X4 | 326296 | - | - | 326286 | - |
| 384238 | Alpine U2.1 - Boost | X4 | 326296 | - | - | 326286 | - |
| 384239 | Alpine U2.1 - Boost | X4 | 326296 | - | - | 326286 | - |
| 384240 | Diablo XL U2.1 - Boost | X4 | 326296 | - | - | 326286 | - |

ERSATZKUGELLAGER

Industriekugellager, zum Beispiel für

- Novatec Naben, linker/rechter Flansch
- Novatec Kassettenfreilaufkörper

REPLACEMENT BEARINGS

sealed bearings, for example for

- Novatec hubs, left and right flange
- Novatec cassette body

Art. 327011
ind. spec. 6902
Innen/Außen-Ø 15/28 mm



Art. 327012
ind. spec. 6000
Innen/Außen-Ø 10/26 mm



Art. 327013
ind. spec. 6901
Innen/Außen-Ø 12/24 mm



Art. 327014
ind. spec. 6001
Innen/Außen-Ø 12/28 mm



Art. 327015
ind. spec. 699
Innen/Außen-Ø 9/20 mm



Art. 327016
ind. spec. 6804
Innen/Außen-Ø 20/32 mm



Art. 327017
ind. spec. 609RS
Innen/Außen-Ø 9/24 mm



Art. 327018
ind. spec. 6802
Innen/Außen-Ø 12/24 mm



Art. 327019
ind. spec. 15267
Innen/Außen-Ø 15/26 mm



| Model | left flange | art. | right flange | art. | cassette body |
|------------------|-------------|--------|--------------|--------|------------------------------------|
| A Type Campy | | | | | 2 x 327013 |
| A Type Shimano | | | | | 2 x 327013 |
| B Type Shimano | | | | | 2 x 327011 |
| B1 Campy | | | | | 2 x 327018 |
| B1 Shimano | | | | | 2 x 327011 |
| B2 Type | | | | | 2 x 327011 |
| A2 Type | | | | | 2 x 327013 |
| F Type Shimano | | | | | 2 x 327019, 1 x 327011 |
| F Type Sram | | | | | 3 x 327019 |
| A141SB | 609RS x 1 | 327017 | 609RS x 1 | 327017 | X |
| A165SBT | 6000 x 1 | 327012 | 6000 x 1 | 327012 | X |
| A166SBT | 6000 x 1 | 327012 | 6000 x 1 | 327012 | X |
| A171SB | 609RS x 1 | 327017 | 609RS x 1 | 327017 | X |
| A291SB | 699 x 1 | 327015 | 699 x 1 | 327015 | X |
| A565SBT | 6000 x 1 | 327012 | 6000 x 1 | 327012 | X |
| A566SBT | 6000 x 1 | 327012 | 6000 x 1 | 327012 | X |
| AS61CB | 699 x 1 | 327015 | 699 x 1 | 327015 | X |
| D032SB | 6001 x 1 | 327014 | 6001 x 1 | 327014 | 2 x 327014 |
| D041SB | 6001 x 1 | 327014 | 6001 x 1 | 327014 | X |
| D042SB | 6001 x 1 | 327014 | 6001 x 1 | 327014 | 2 x 327014 |
| D101SB | 6902 x 1 | 327011 | 6902 x 1 | 327011 | 2 x 327011 |
| D102SB | 6902 x 1 | 327011 | 6902 x 1 | 327011 | 2 x 327011 |
| D142SB-X12 | 6902 x 1 | 327011 | 6902 x 1 | 327011 | 1 x 327019 |
| D162SB-SL-X12 | 6902 x 1 | 327011 | 6902 x 1 | 327011 | only change complete cassette-body |
| D201SB | 6902 x 1 | 327011 | 6902 x 1 | 327011 | X |
| D202SB | 6902 x 1 | 327011 | 6902 x 1 | 327011 | 2 x 327011 |
| D252SB | 6001 x 1 | 327014 | 6001 x 1 | 327014 | 2 x 327014 |
| D411CB | 6803 x 1 | | 6803 x 1 | | X |
| D412CB | 15267 x 1 | 327019 | 15267 x 1 | 327019 | 2 x 327019 |
| D462SB | 6902 x 1 | 327011 | 6902 x 1 | 327011 | 3 x 327019 |
| D462SB-B12 | 6902 x 1 | 327011 | 6902 x 1 | 327011 | 3 x 327019 |
| D541SB | 6804 x 1 | 327016 | 6804 x 1 | 327016 | X |
| D542SB | 6902 x 1 | 327011 | 6809 x 1 | | 2 x 327011 |
| D711SB | 6902 x 1 | 327011 | 6902 x 1 | 327011 | X |
| D712SB | 6902 x 1 | 327011 | 6902 x 1 | 327011 | 2 x 327011 |
| D712SB/S45-B12 | 6902 x 1 | 327011 | 6902 x 1 | 327011 | 2 x 327011 |
| D722SB | 6902 x 1 | 327011 | 6902 x 1 | 327011 | 2 x 327011 |
| D771SB | 6902 x 1 | 327011 | 6902 x 1 | 327011 | X |
| D772SB | 6902 x 1 | 327011 | 6902 x 1 | 327011 | 2 x 327011 |
| D791SB | 6902 x 1 | 327011 | 6902 x 1 | 327011 | X |
| D791SB-B12 | 6902 x 1 | 327011 | 6902 x 1 | 327011 | X |
| D792SB | 6902 x 1 | 327011 | 6902 x 1 | 327011 | 2 x 327011 |
| D811SB-15 | 6902 x 1 | 327011 | 6902 x 1 | 327011 | X |
| D881SB | 6804 x 1 | 327016 | 6804 x 1 | 327016 | X |
| D882SB | 6902 x 1 | 327011 | 6902 x 1 | 327011 | 2 x 327011 |
| D932SB-B12 | 6902 x 1 | 327011 | 6902 x 1 | 327011 | 2 x 327018 |
| DH61SB | 6804 x 1 | 327016 | 6804 x 1 | 327016 | X |
| DH82SB | 6902 x 1 | 327011 | 6902 x 1 | 327011 | 2 x 327011 |
| F162SB | 6001 x 1 | 327014 | 6001 x 1 | 327014 | 2 x 327013 |
| F172SB | 6901 x 1 | 327013 | 6001 x 1 | 327014 | 2 x 327013 |
| F482SB | 6802 x 1 | 327018 | 6902 x 1 | 327011 | 2 x 327011 |
| FS62CB | 6802 x 1 | 327018 | 15267 x 1 | 327019 | 2 x 327019 |
| XDS641SB-B15 | 6804 x 1 | 327016 | 6804 x 1 | 327016 | X |
| XDS642SB-B12-ABG | 6903 x 1 | 327021 | 6903 x 1 | 327021 | 2 x #17287 |

311878 passend für Exustar Pedale Art. 311855,
Maße: außen 12,94 mm, innen
5,67 mm, Dicke 4,97 mm

suitable for Exustar pedals art. 311855,
size: outside 12.94 mm, inside 5.67 mm,
width 4.97 mm



ind. spec. 686ZZ
Innen/Außen-Ø 5,67/12,94 mm



messingschlager

Haßbergstr. 45
96148 Baunach - Germany
Tel.: +49 (0) 95 44 94 44 - 0
www.novatec.messingschlager.com

Vertrieb / distribution: